

“KONZERT VI”

”harp”

Piece for 4 musicians, 1 Computer and 4 Speakers

Winfried Ritsch





23.November 1999 - May 8, 2000

The harp should be microphoned by a pickup or the microphone of the harp should be positioned not much farther than 1 m in front and 1.5 m in height. The harp is amplified through the speakers.

All sounds should be played not to loud. The phrases should be played in blocks, like you where just producing a sounds in a studio. The player has a stop watch which is started synchron to with all others at time 0'00' .

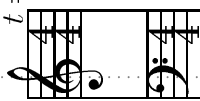
Table of Symbols

Timeline starts with '0'0" for synchronizing the stop watch

effect:	very strong	middlelight	no effect	-no damping
damp position	very high	high	middle	bottom
Harp	 <p>$t =$ <i>Tempo(Quarter = ...)</i></p>			 <p>Example for volume graph (cresc. - decr.), use only if possible (eg. not on pizz.,etc.)</p>
	<p>Clefs for Notes omitted in score</p>	<p>colors group notes to phrases with same tempo clef and meter for whole piece</p>		
	<p>Example for computer voice can be used to follow score</p>			

00
90
80
70
60
50

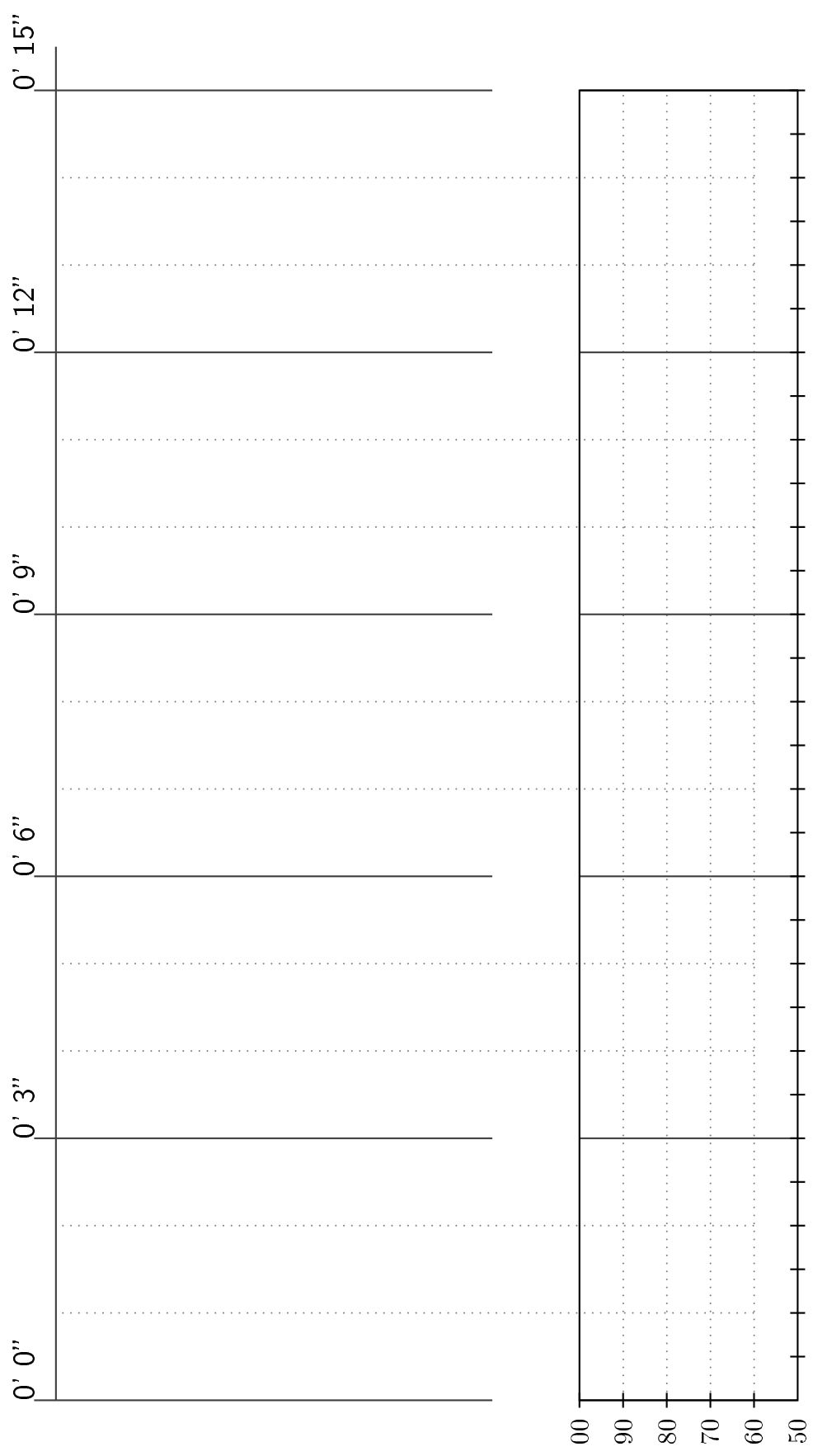

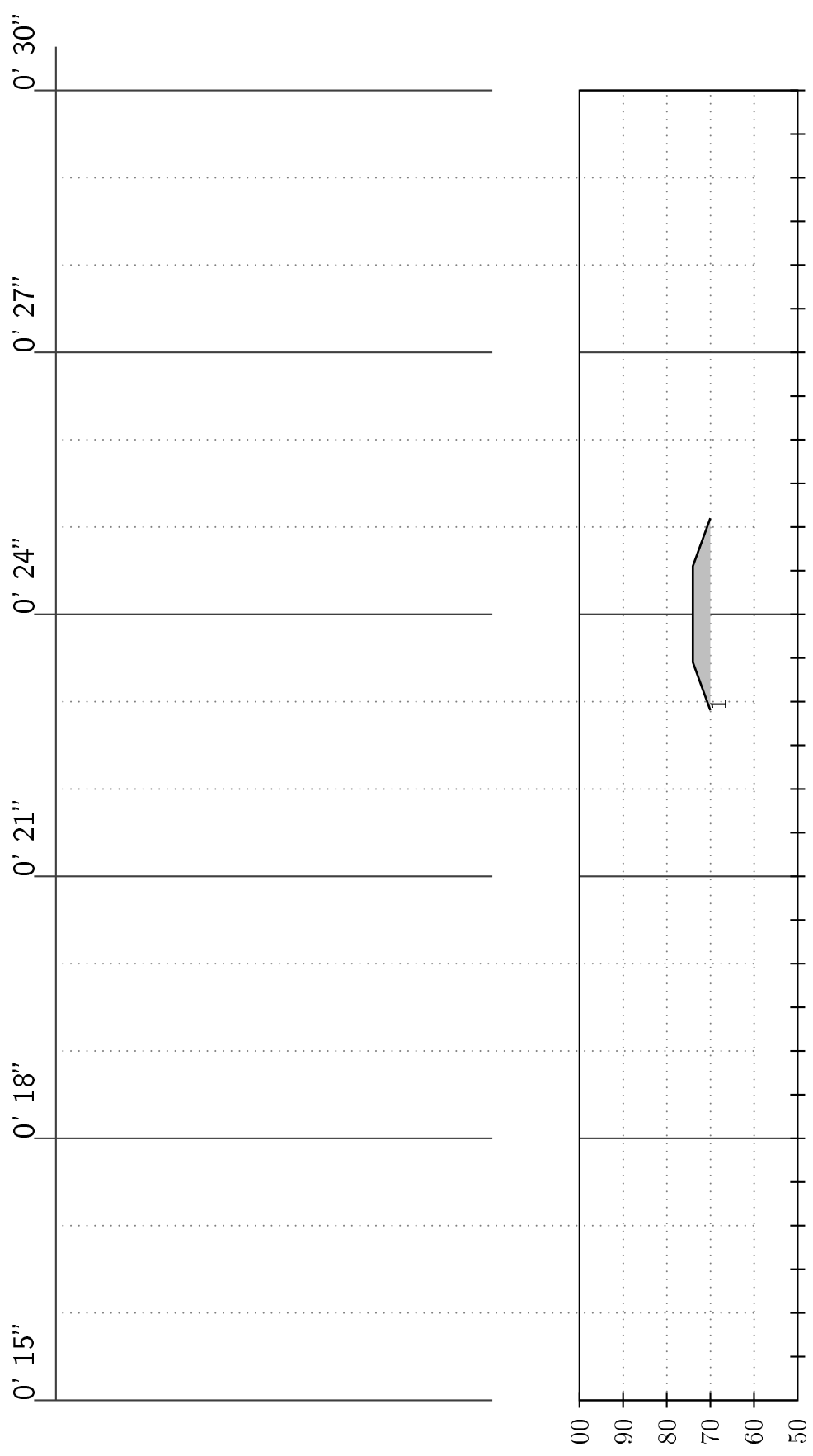

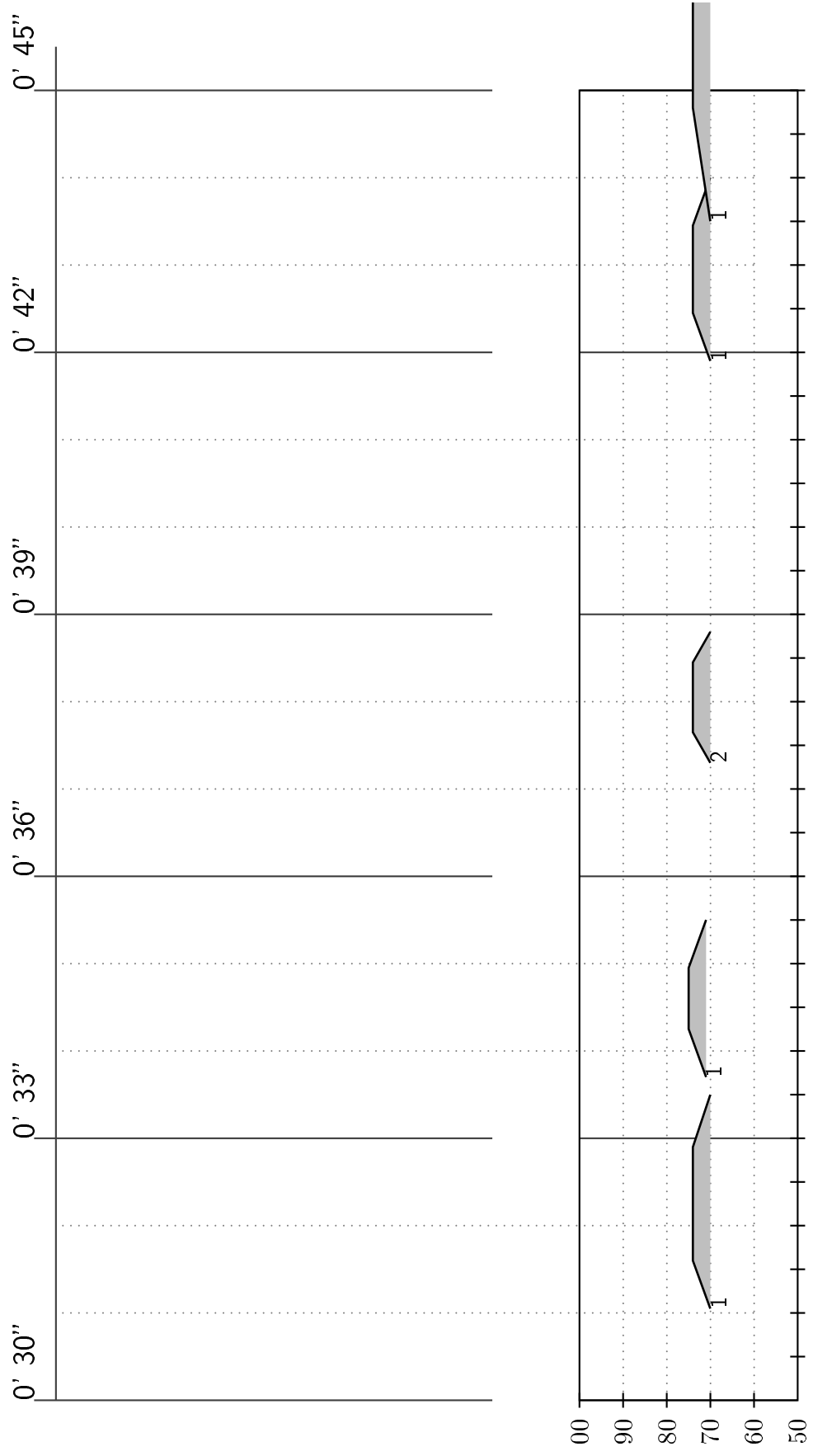

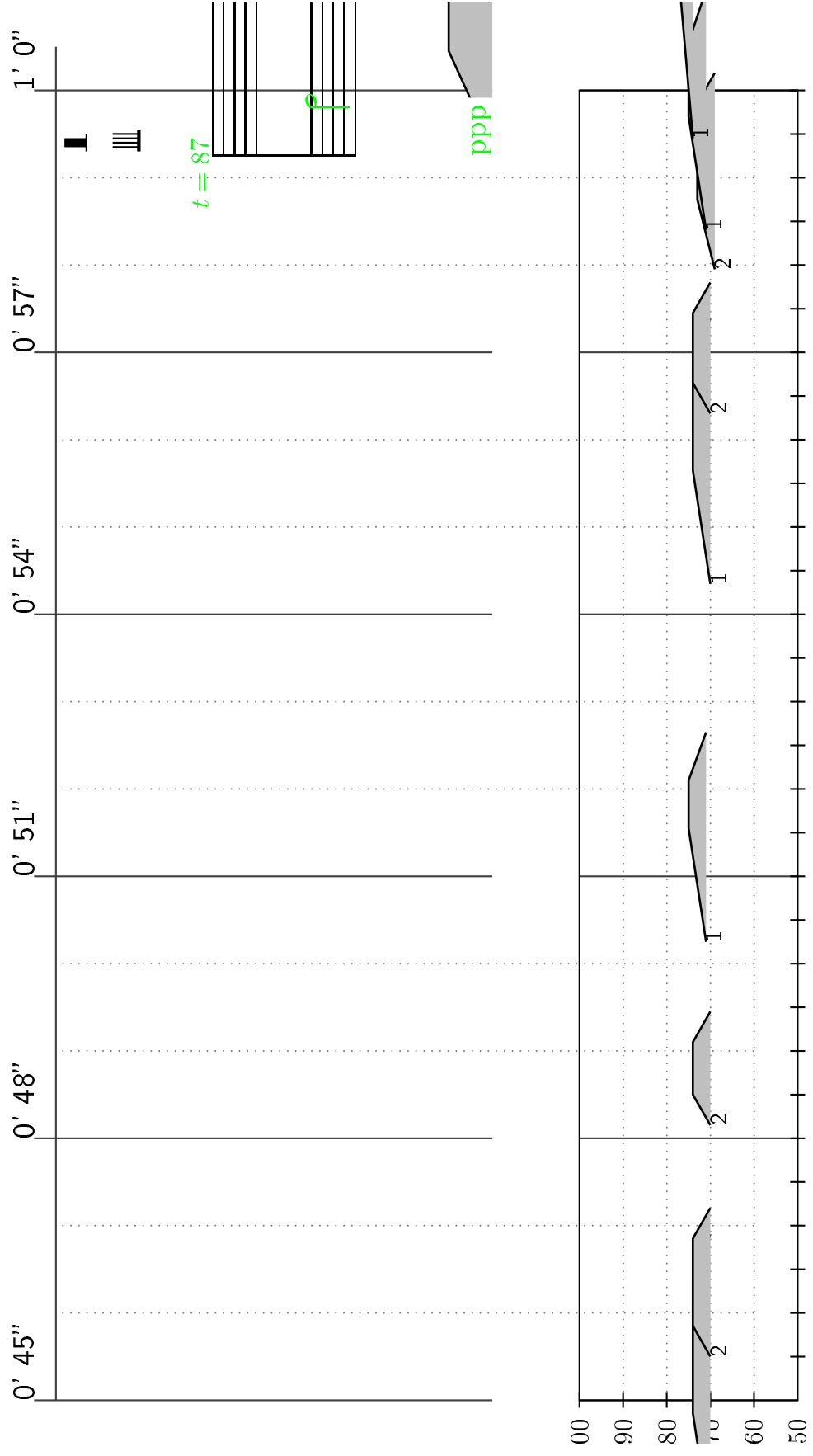

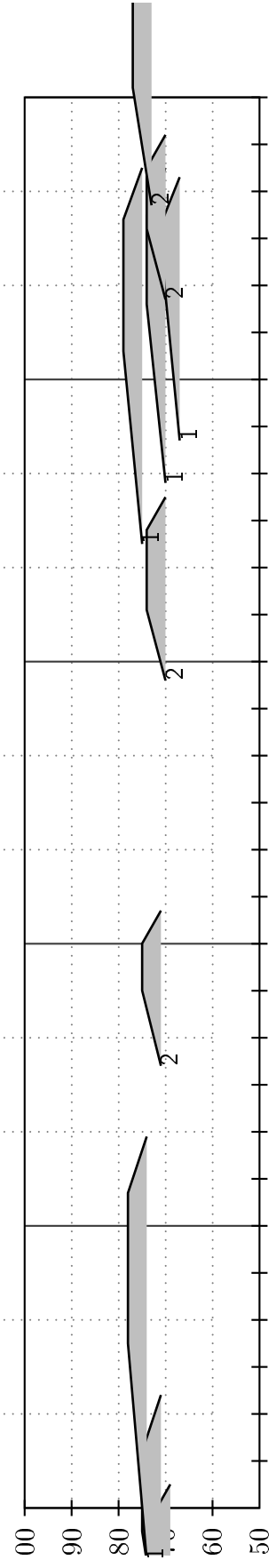
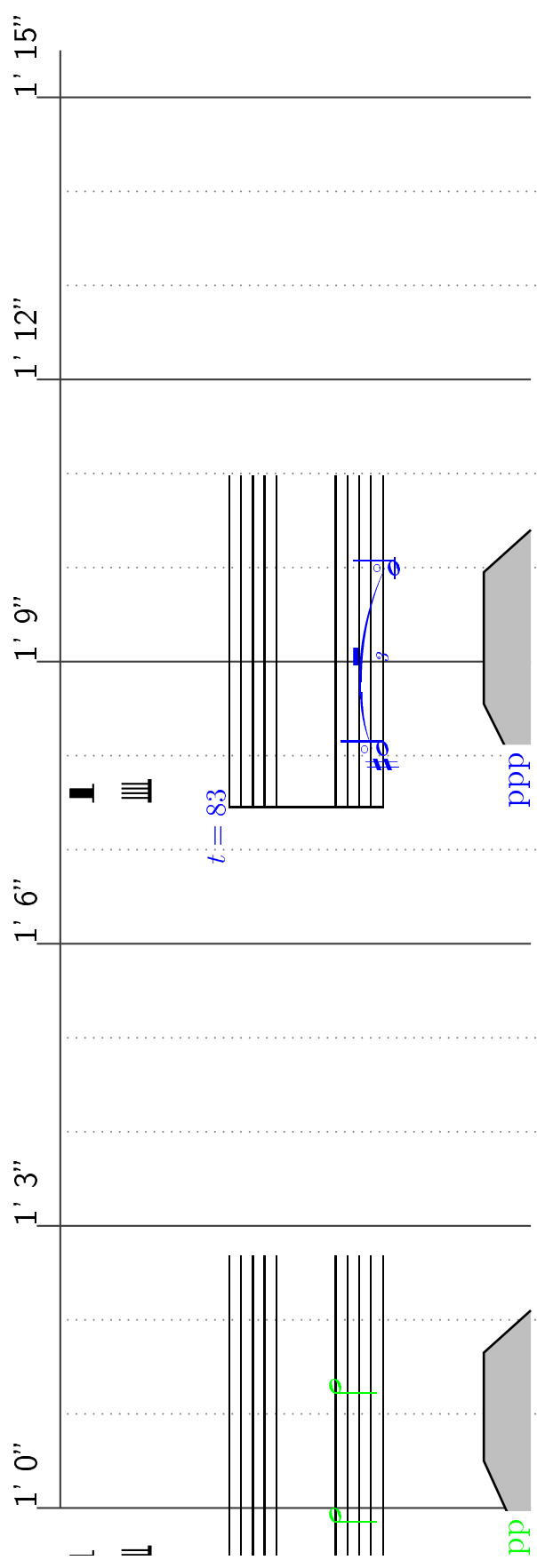

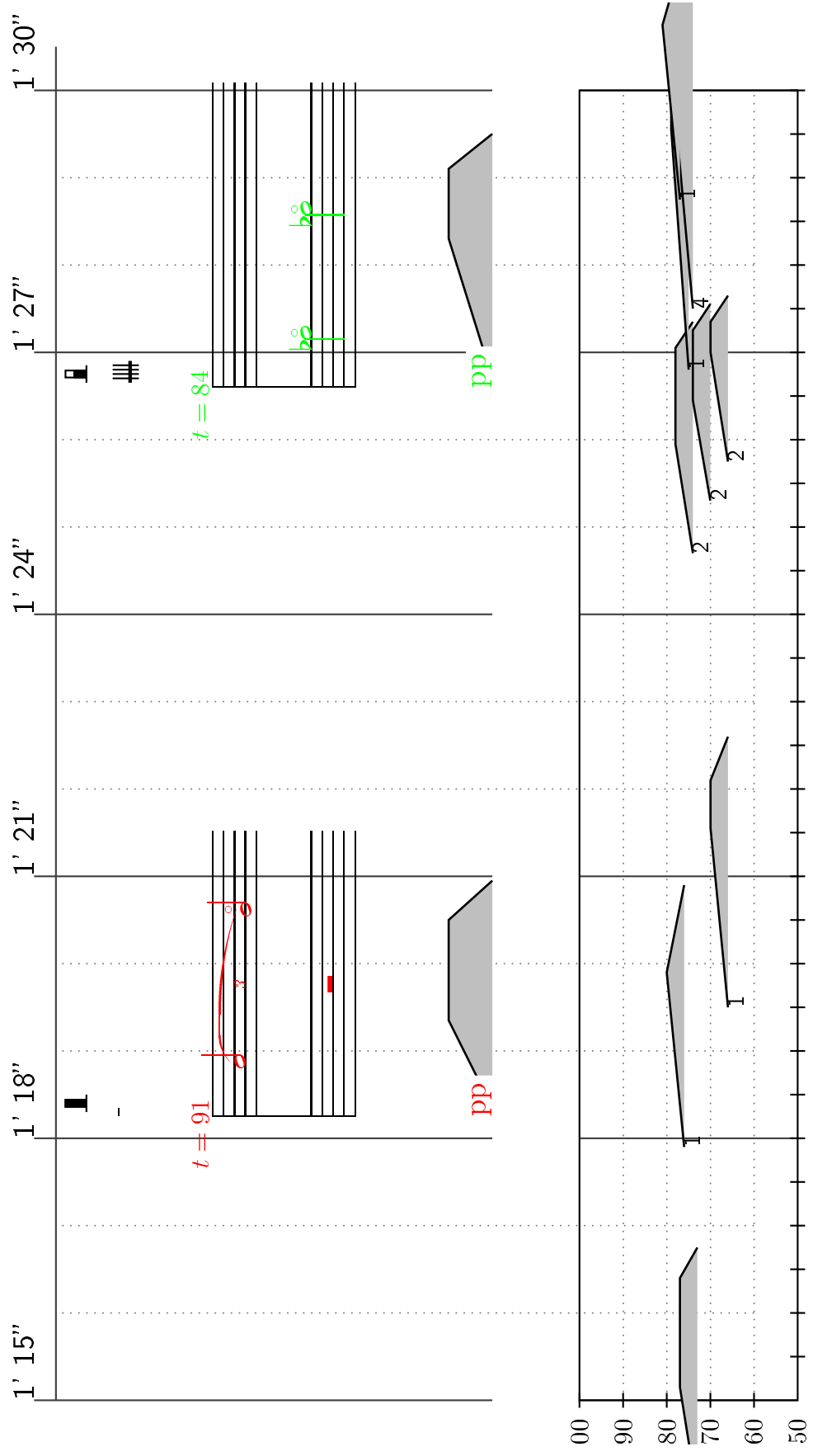

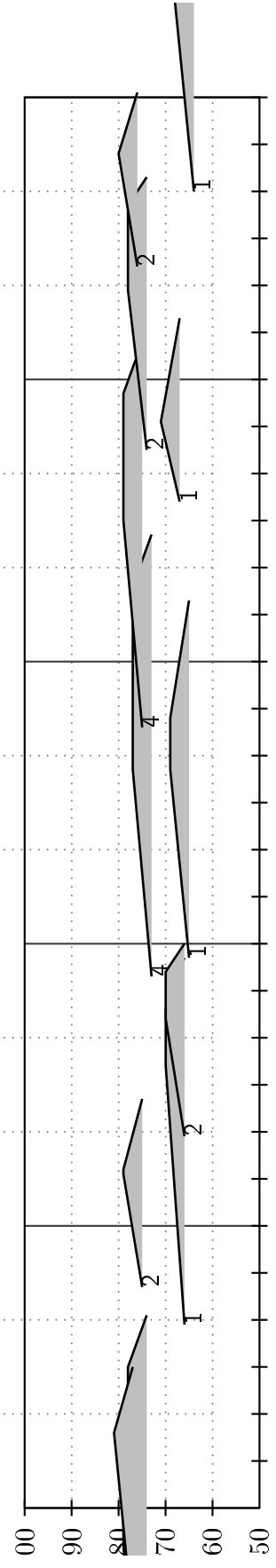
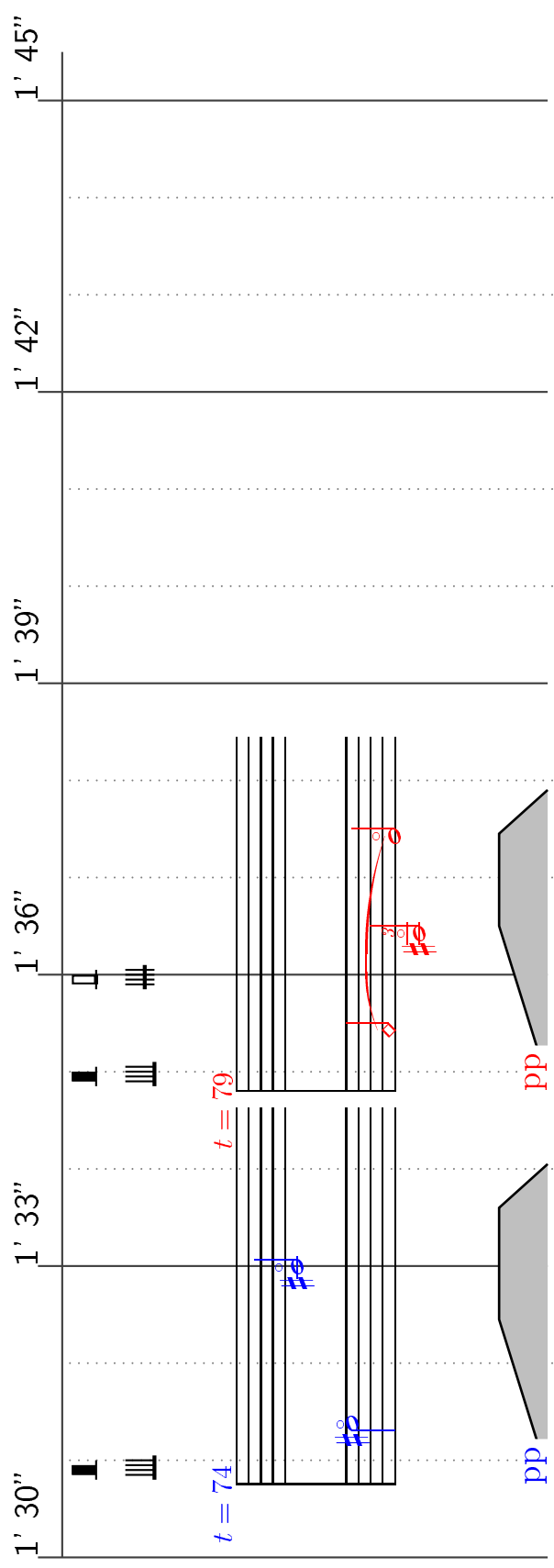

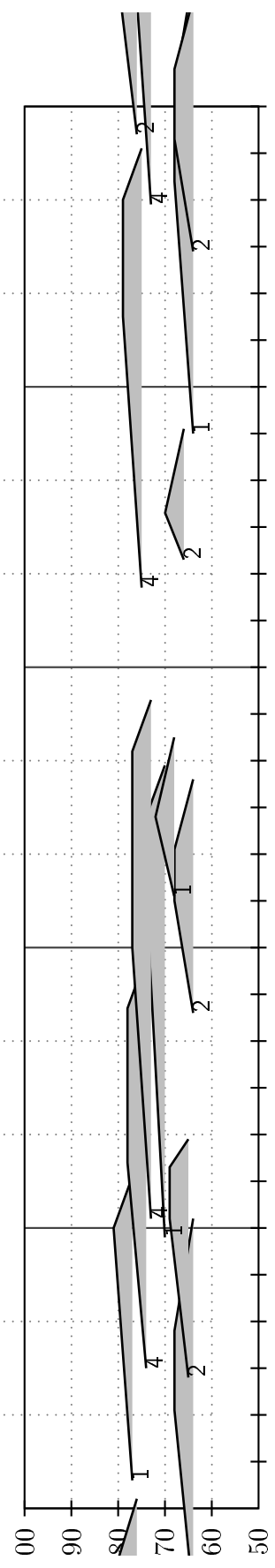
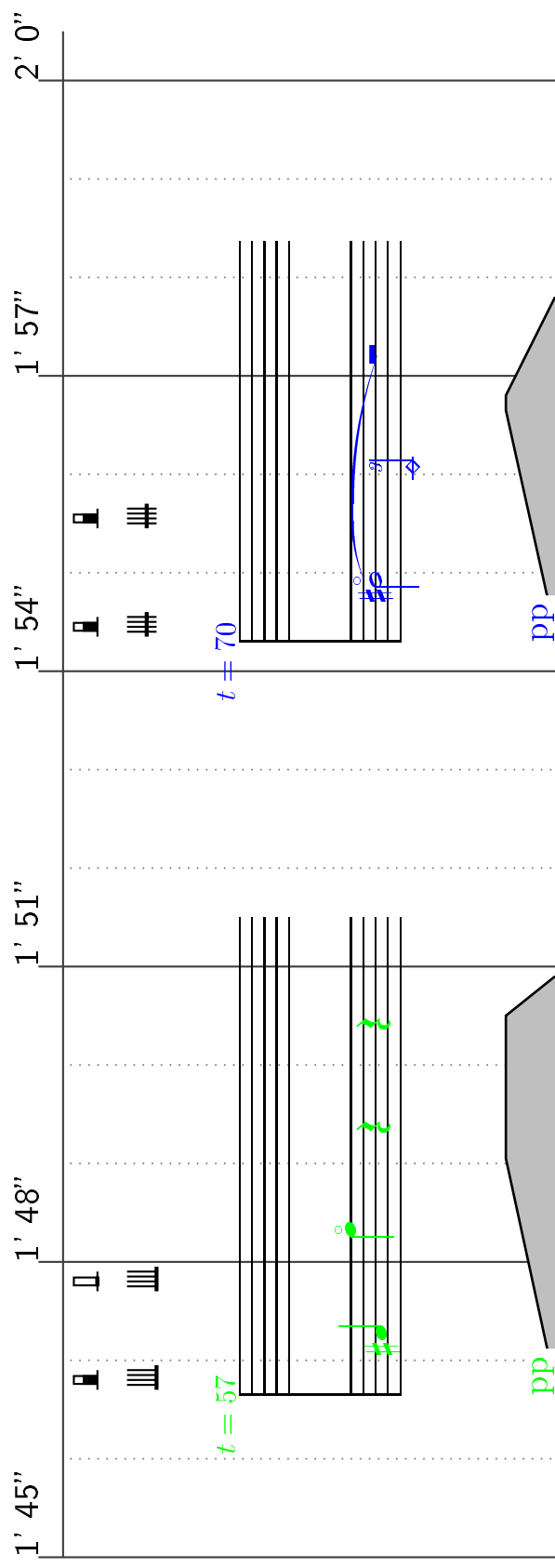

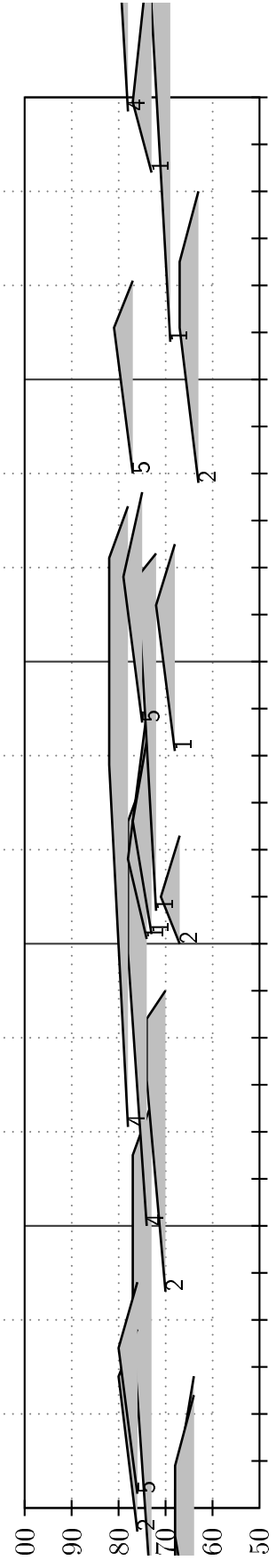
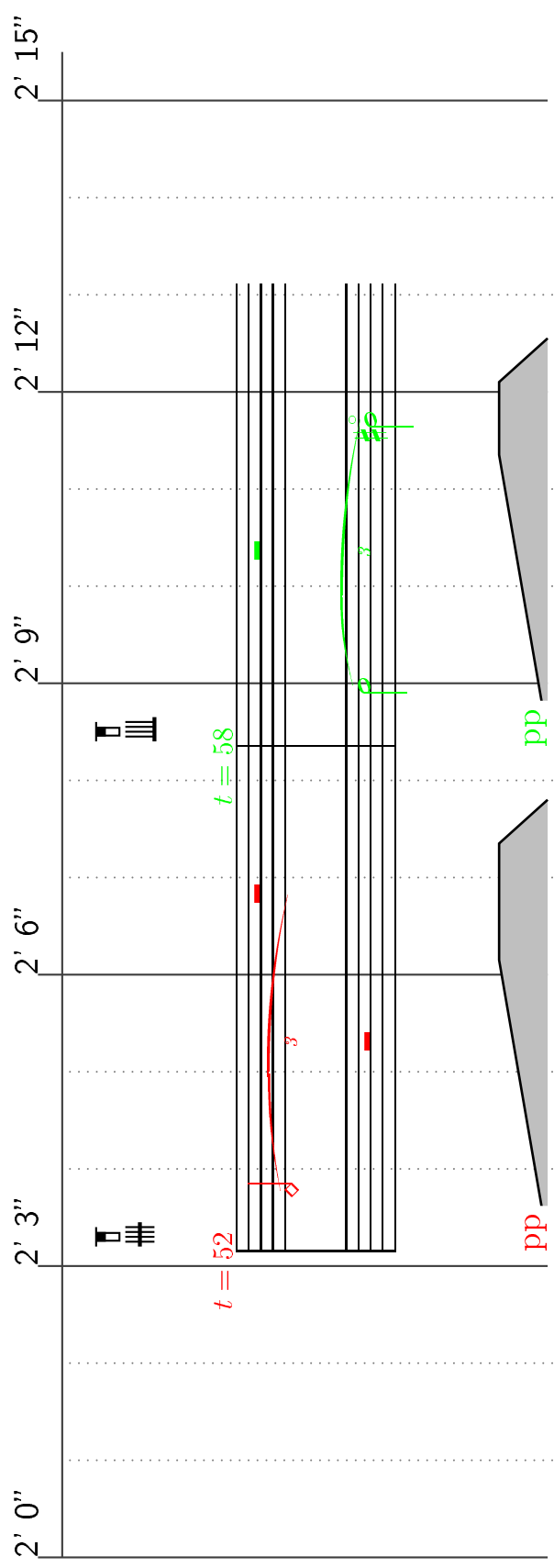

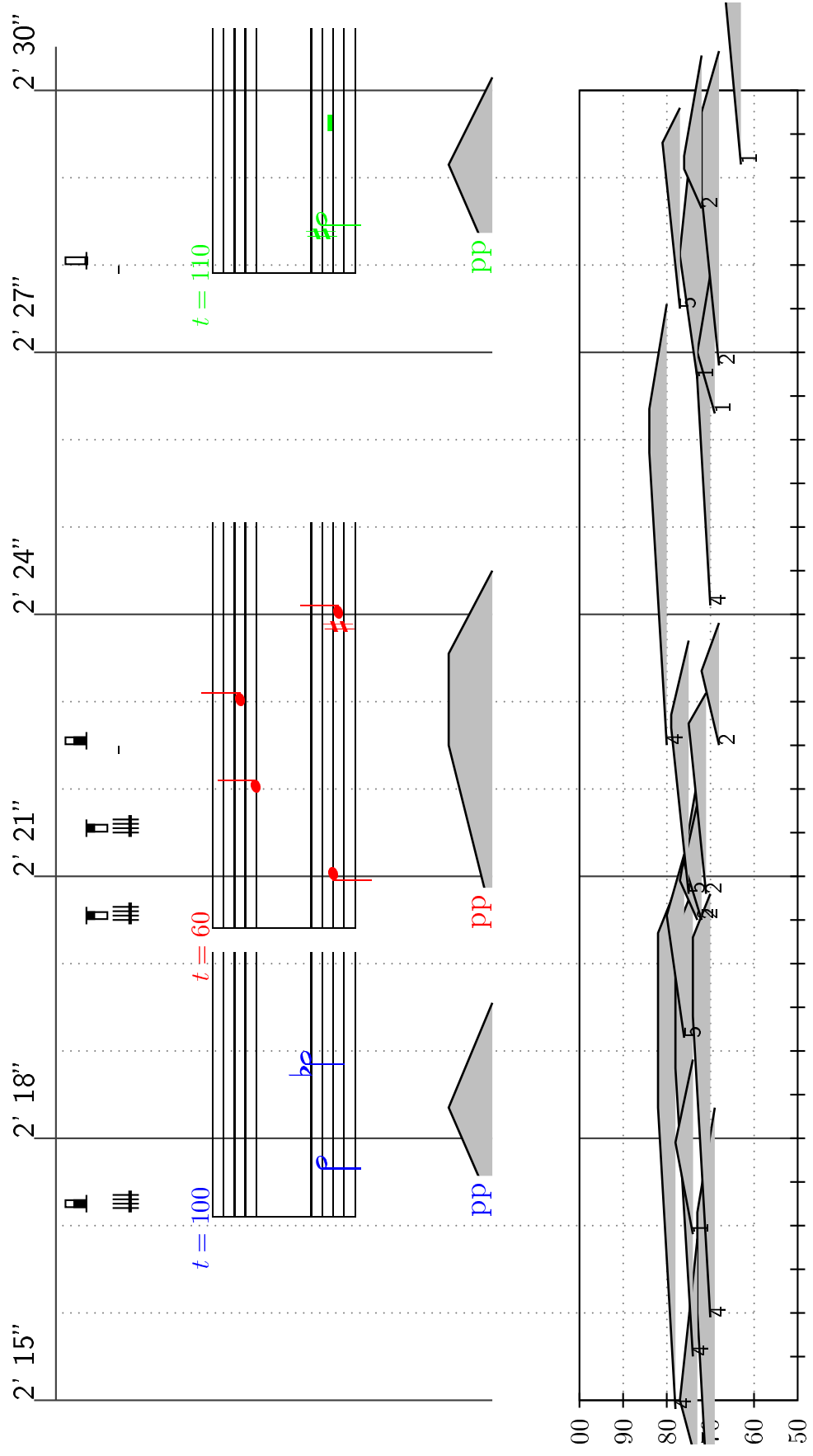

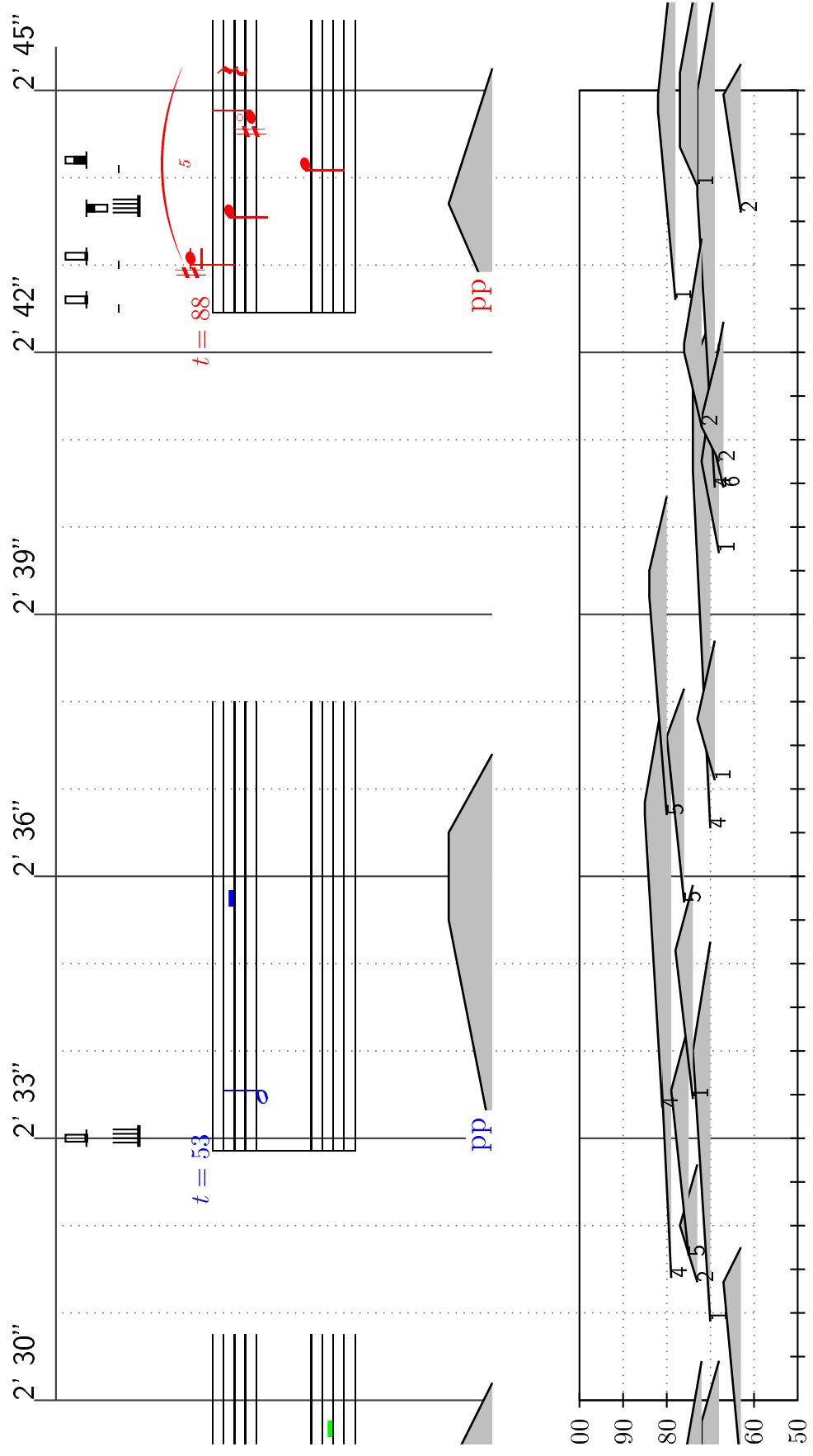

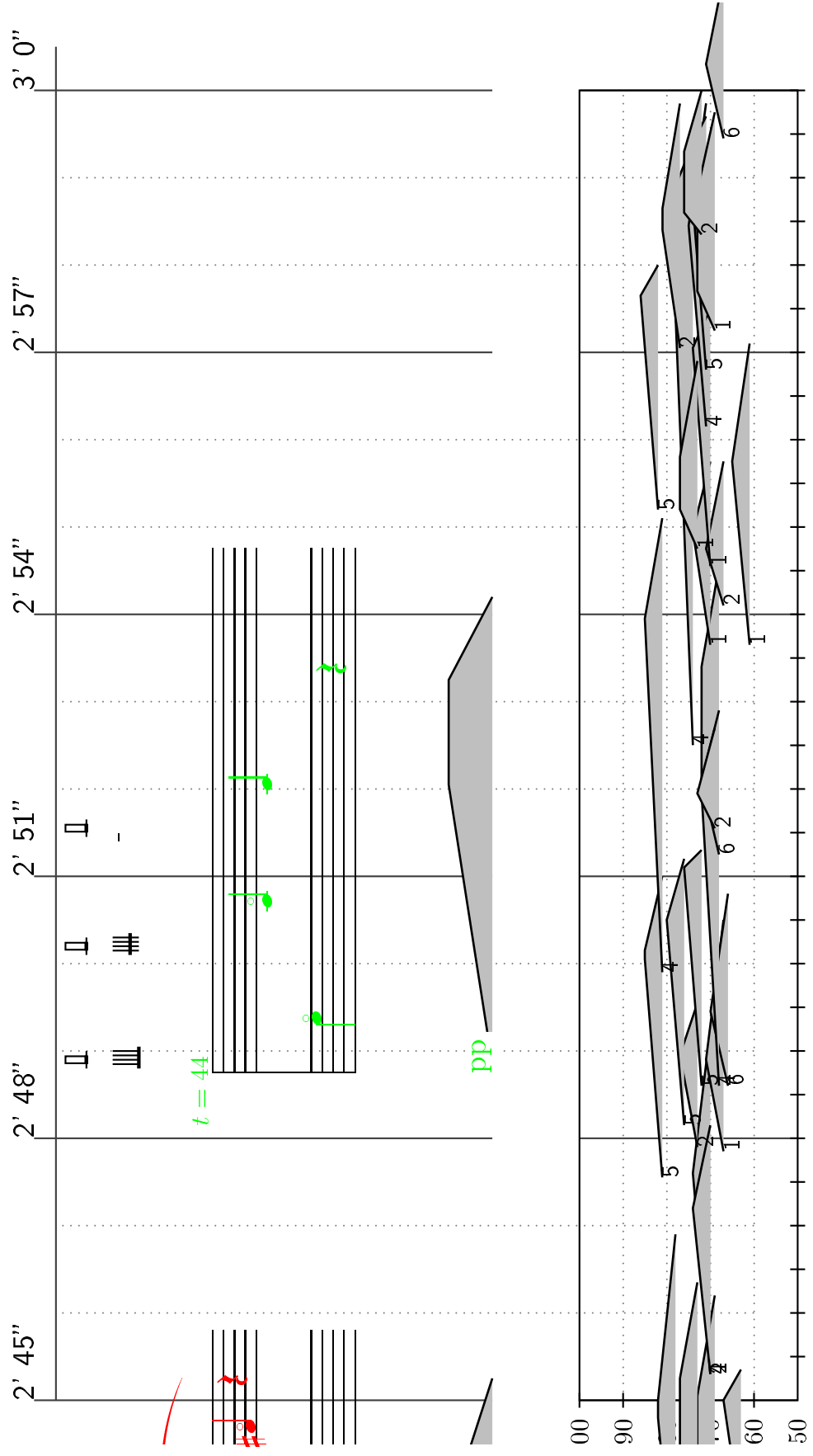

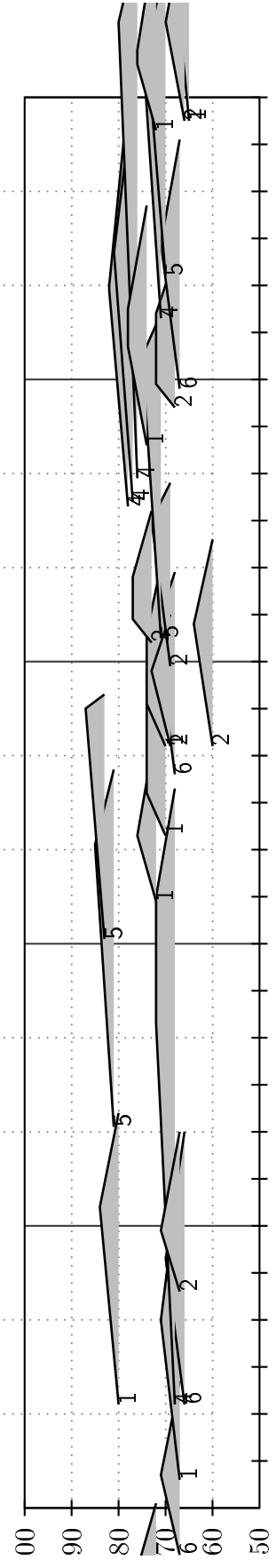
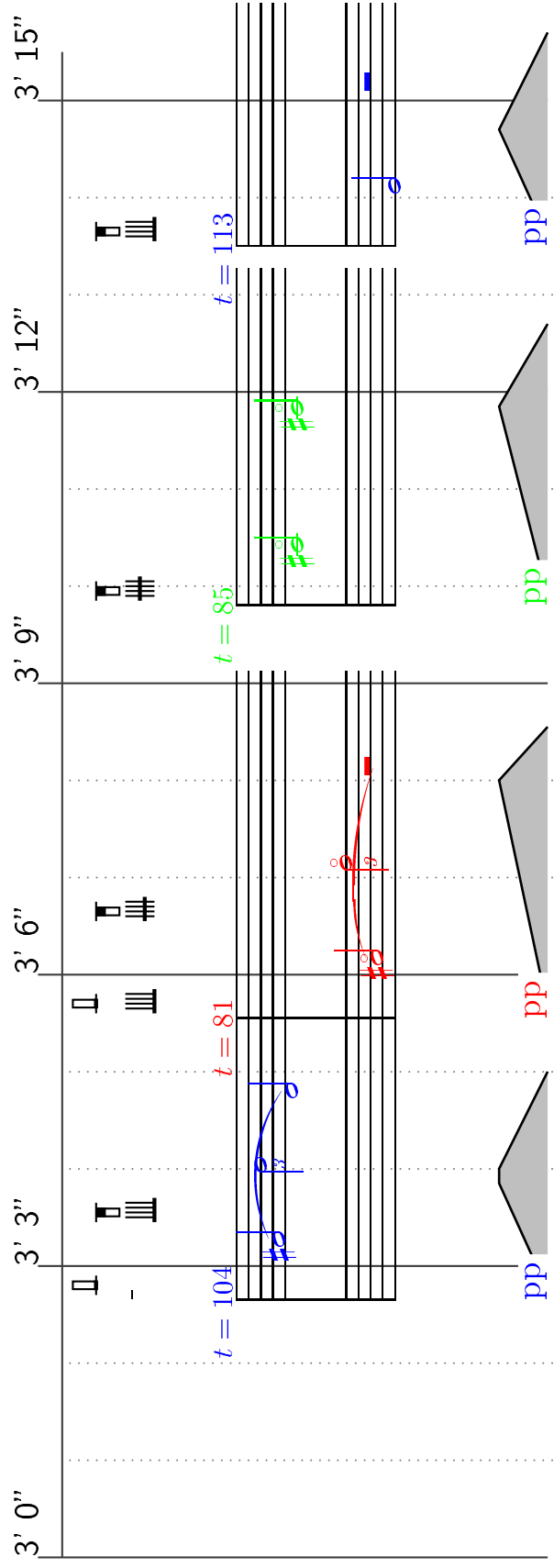

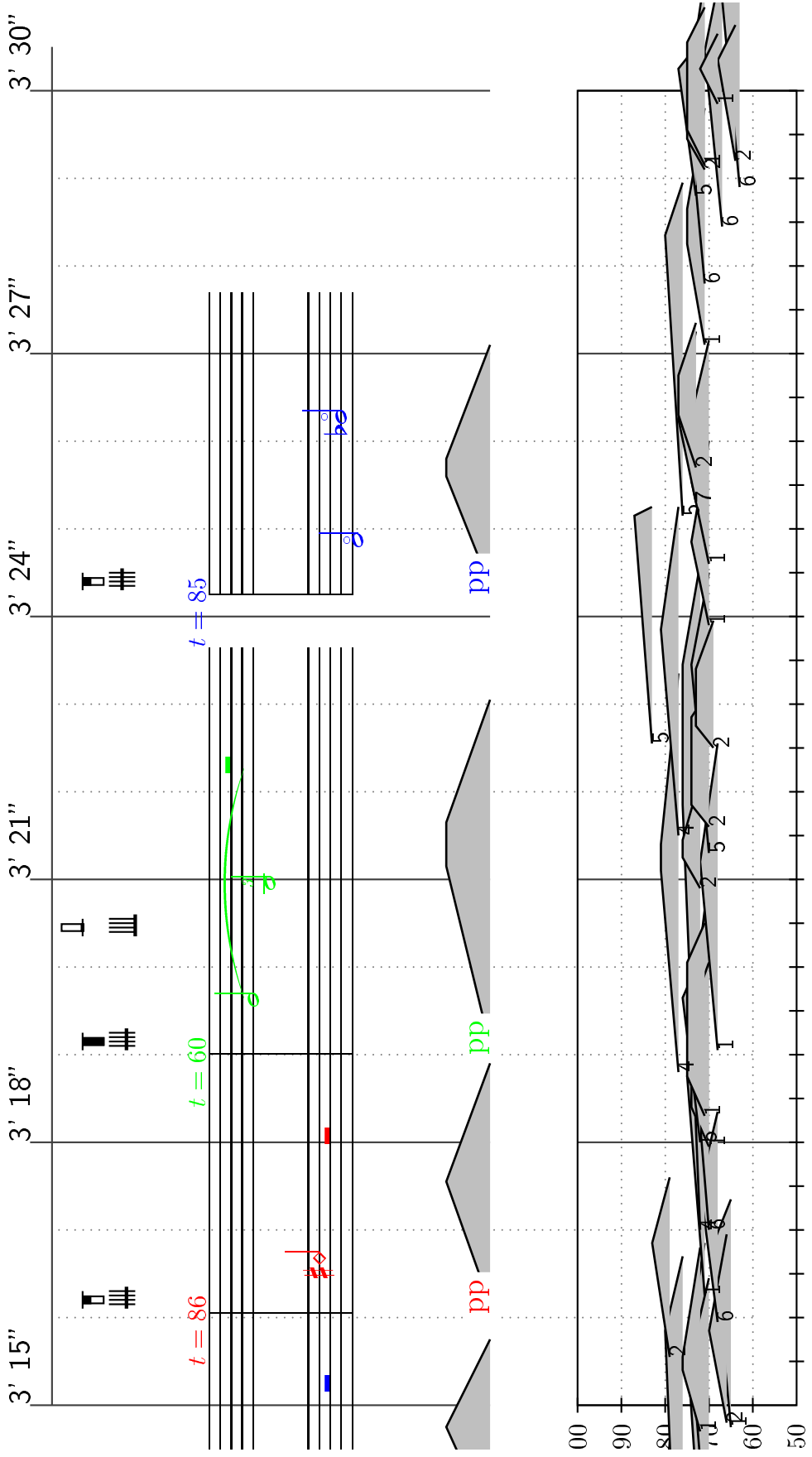

Musical score for strings, divided into four time segments: 3' 45", 3' 48", 3' 51", and 3' 54". The score includes staves for woodwinds (flute and clarinet) and strings. Time markers are labeled as $t = 89$ (green), $t = 102$ (blue), and $t = 102$ (red). Dynamic markings include pp (pianissimo) in green, blue, and red. The score shows various musical notations such as notes, rests, and articulation marks.

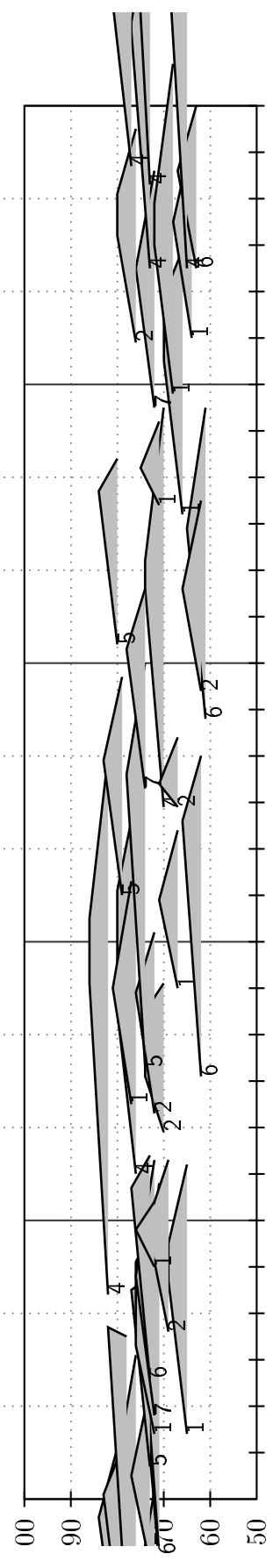

Musical score for four time segments: 4' 0'', 4' 3'', 4' 6'', 4' 9'', 4' 12'', and 4' 15''.
 - 4' 0'': $t = 103$, notes in green, dynamic pp , $8va$ marking.
 - 4' 3'': $t = 86$, notes in blue, dynamic pp .
 - 4' 6'': notes in blue, dynamic pp .
 - 4' 9'': $t = 80$, notes in red, dynamic p .
 - 4' 12'': notes in red, dynamic pp .
 - 4' 15'': $t = 156$, notes in green, dynamic pp .

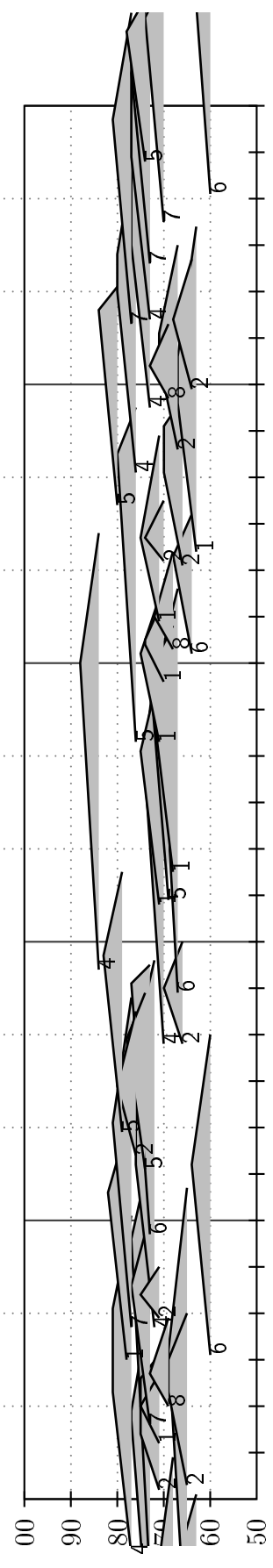

4' 30" 4' 33" 4' 36" 4' 39" 4' 42" 4' 45"

The musical score shows three staves for flute, clarinet, and bassoon. The flute part has blue notes with a slur and a circled 'p' at 4' 33". The clarinet part has red notes with a slur and a circled 'pp' at 4' 36". The bassoon part has green notes with a slur and a circled 'p' at 4' 42". Time stamps are provided for each section: $t = 89$ (blue), $t = 101$ (red), and $t = 95$ (green).

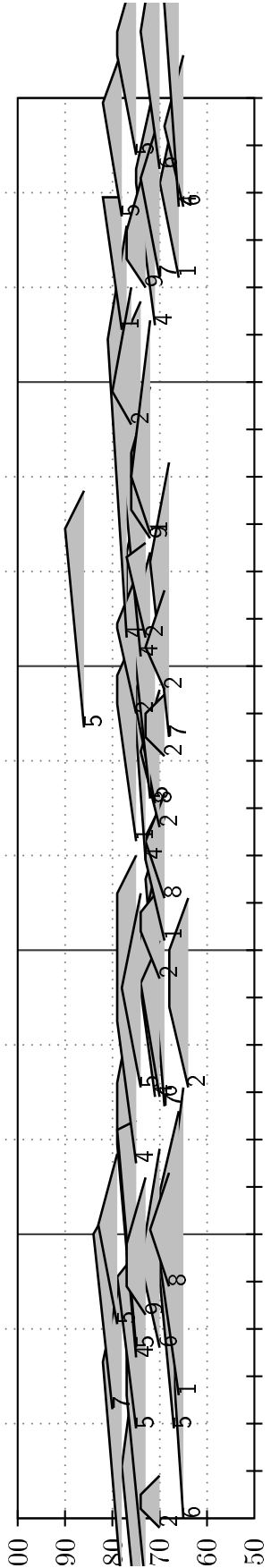

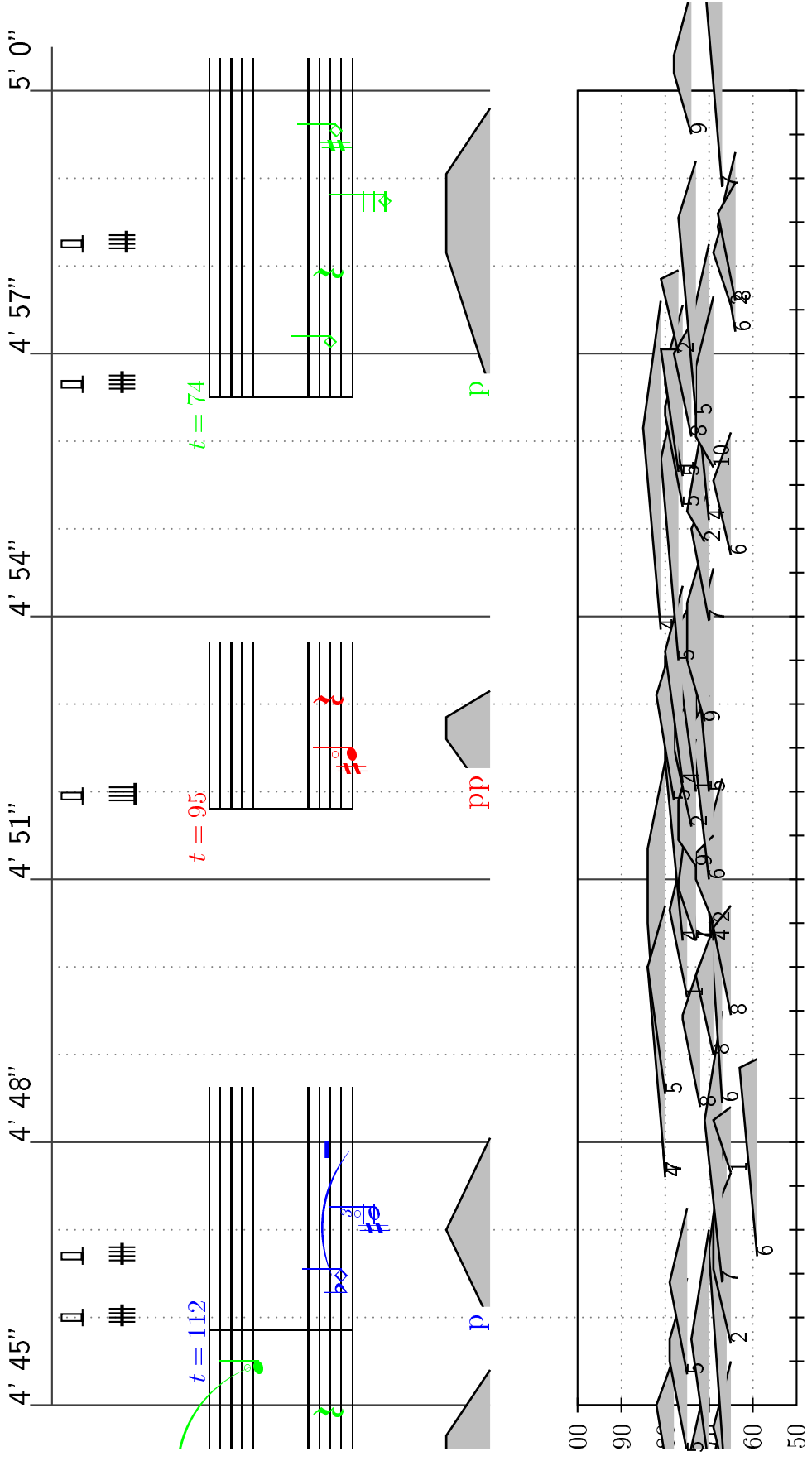

4' 45"

4' 48"

4' 51"

4' 54"

5' 0"

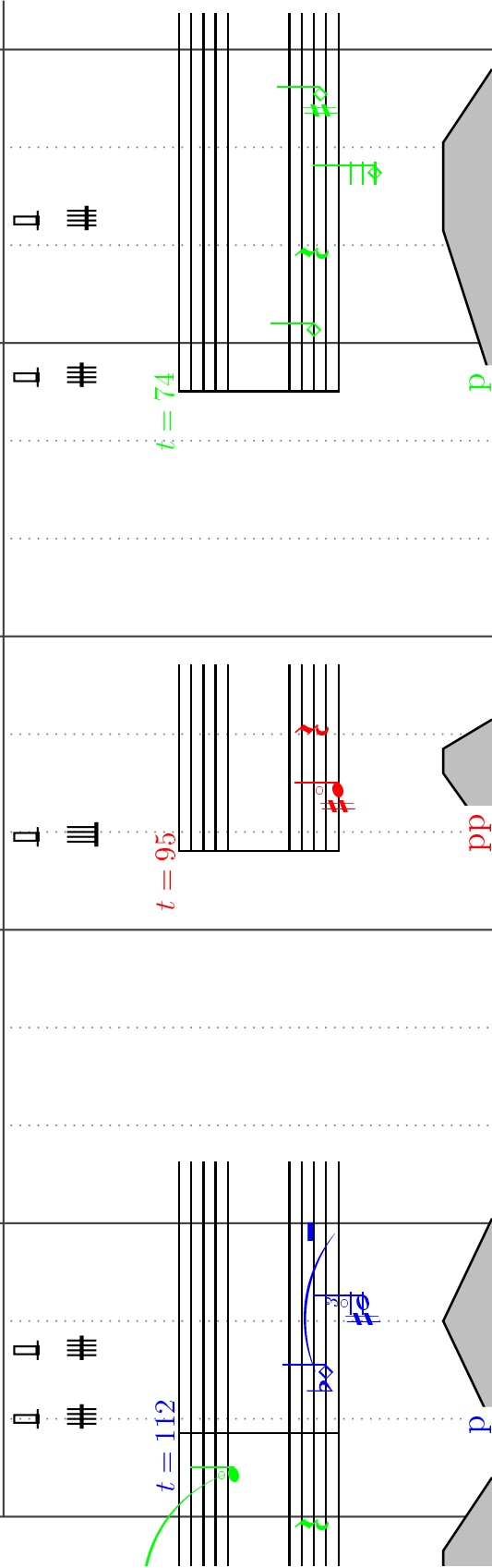

4' 45"

4' 48"

4' 51"

4' 54"

5' 0"

$t = 112$

$t = 95$

$t = 74$

p

pp

p

00
90
80
70
60
50

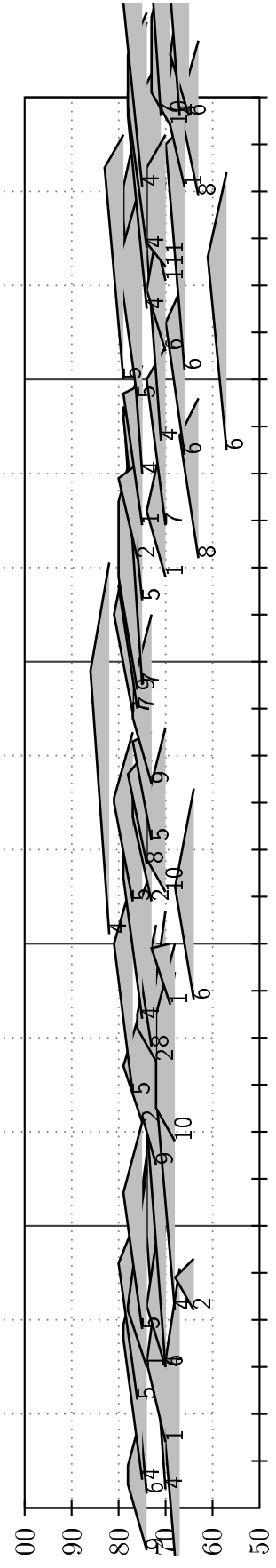
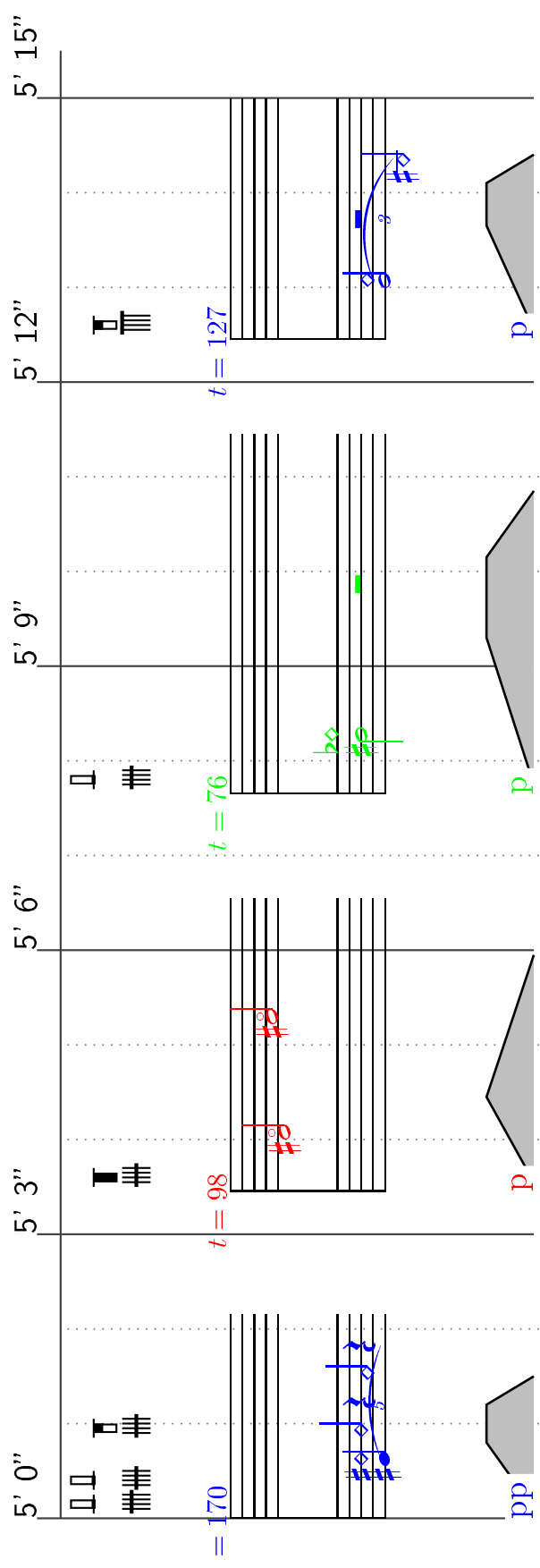

5' 15" 5' 18" 5' 21" 5' 24" 5' 27" 5' 30"

The musical score consists of three staves. The top staff is for piano (p), the middle for violin (v), and the bottom for cello (c). Time markers are placed at 5' 15", 5' 18", 5' 21", 5' 24", 5' 27", and 5' 30". Dynamic markings include $t = 89$ (red), $t = 91$ (red), $t = 105$ (blue), and $t = 91$ (green). The score shows various notes, rests, and articulation marks across the staves.

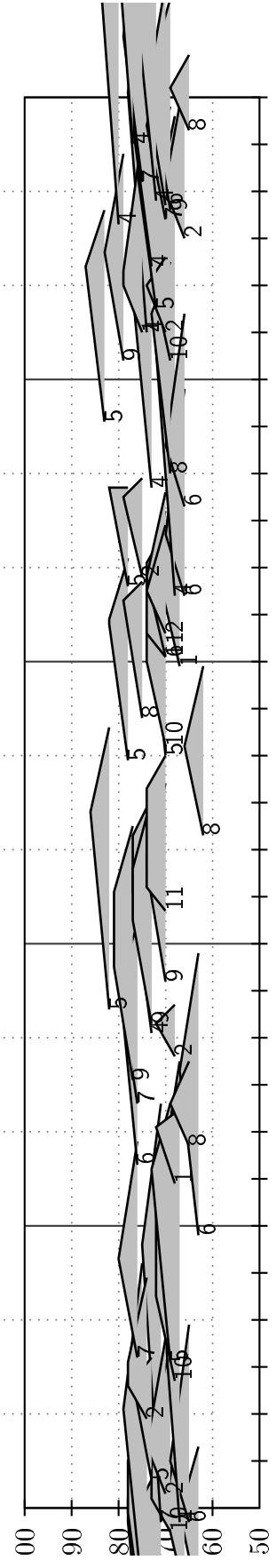

Musical score for strings, showing four measures with time markers and dynamic markings. The score is divided into four measures by vertical lines, with time markers at the top: 5' 30", 5' 33", 5' 36", 5' 39", 5' 42", and 5' 45".

- 5' 30" - 5' 33":** First measure. Dynamic marking p (piano) in red. Time marker $t = 127$ in green.
- 5' 33" - 5' 36":** Second measure. Dynamic marking p (piano) in green. Time marker $t = 88$ in blue.
- 5' 36" - 5' 39":** Third measure. Dynamic marking p (piano) in blue. Time marker $t = 88$ in blue.
- 5' 39" - 5' 42":** Fourth measure. Dynamic marking p (piano) in red. Time marker $t = 103$ in red.

The score includes staves for strings (I, II, III, IV) and dynamic markings (p) in various colors (red, green, blue).

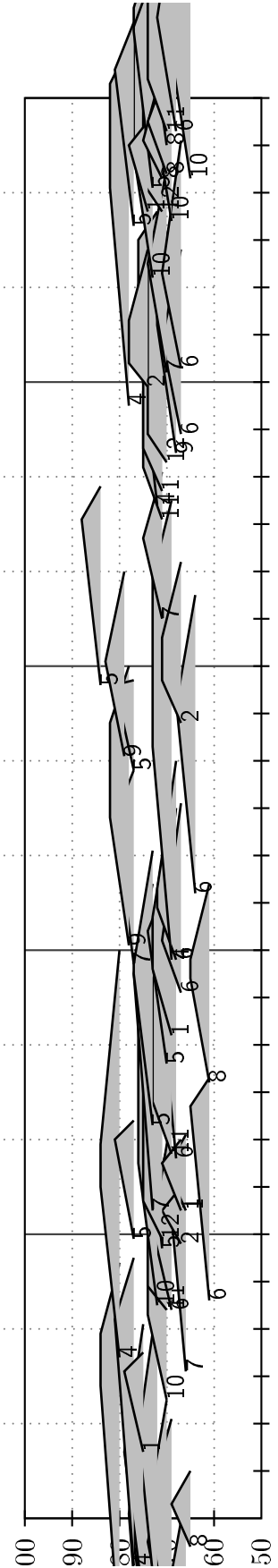

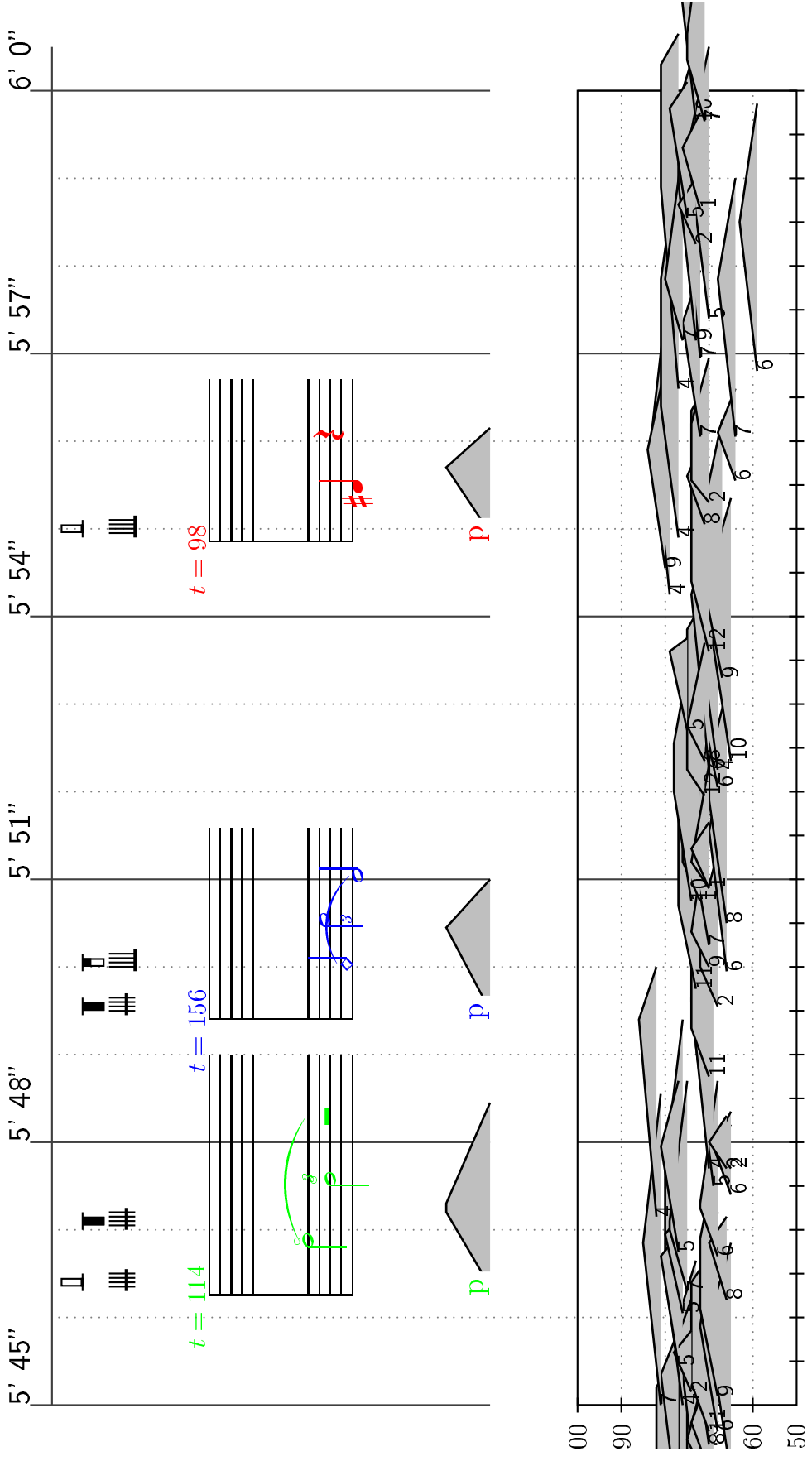

6' 30" 6' 33" 6' 36" 6' 39" 6' 42" 6' 45"

The musical score consists of two staves. The left staff has a treble clef and a key signature of one sharp (F#). The right staff has a bass clef and a key signature of one sharp (F#). The score is divided into measures by vertical lines, with time markers at the top: 6' 30", 6' 33", 6' 36", 6' 39", 6' 42", and 6' 45".

- At 6' 30", there is a green arrow pointing to a note on the left staff.
- At 6' 33", there is a blue arrow pointing to a note on the left staff, with the text $t = 139$ above it.
- At 6' 36", there is a blue arrow pointing to a note on the left staff, with the text $t = 139$ above it. Below the right staff, there is a dynamic marking mp .
- At 6' 39", there is a red arrow pointing to a note on the left staff, with the text $t = 81$ above it. Below the right staff, there is a dynamic marking p .
- At 6' 42", there is a red arrow pointing to a note on the right staff, with a red squiggle below it.

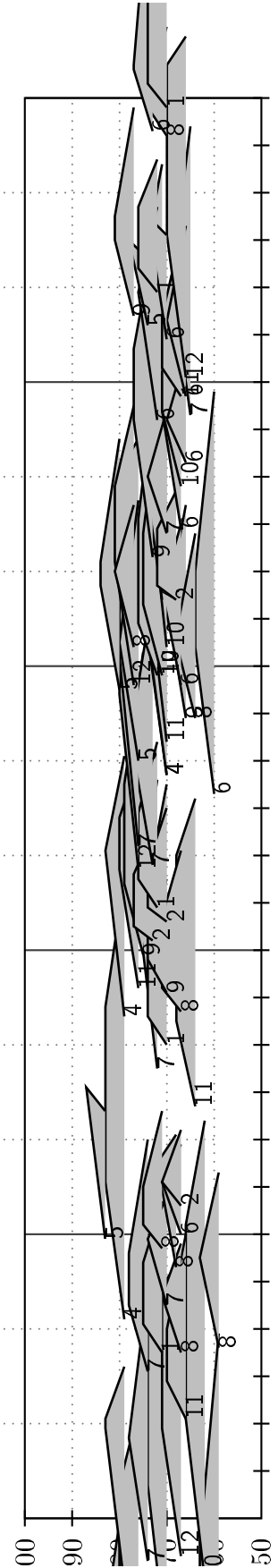

Musical score for four staves. Time markers are placed at the top of each staff: 6' 45", 6' 48", 6' 51", 6' 54", 6' 57", and 7' 0".
 - At 6' 45": $t = 120$ (green), dynamic *mp* (green).
 - At 6' 51": $t = 109$ (blue), dynamic *mp* (blue).
 - At 6' 54": $t = 161$ (red), dynamic *p* (red).
 - At 6' 57": $t = 116$ (green), dynamic *mp* (green).
 The score includes various musical notations such as notes, rests, and dynamic markings.

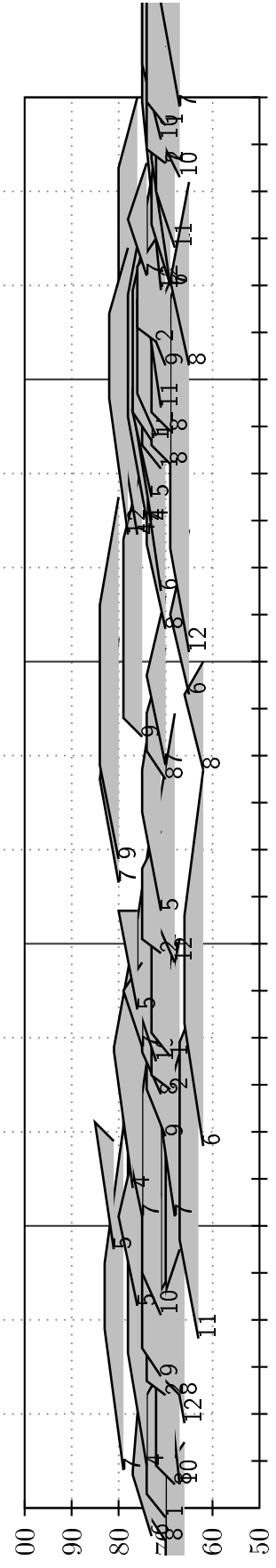

Musical score for a horn instrument, showing four measures with time markers and dynamic markings. The time markers are 7' 0", 7' 3", 7' 6", 7' 9", 7' 12", and 7' 15". The score includes a key signature of one sharp (F#) and a common time signature (C). The dynamic markings are *mp* (mezzo-piano) and *mp* (mezzo-piano). The notes are:

- 7' 0": G4 (quarter note), A4 (quarter note), B4 (quarter note), C5 (quarter note). Dynamic: *mp*.
- 7' 3": G4 (quarter note), A4 (quarter note), B4 (quarter note), C5 (quarter note). Dynamic: *mp*.
- 7' 6": G4 (quarter note), A4 (quarter note), B4 (quarter note), C5 (quarter note). Dynamic: *mp*.
- 7' 9": G4 (quarter note), A4 (quarter note), B4 (quarter note), C5 (quarter note). Dynamic: *mp*.
- 7' 12": G4 (quarter note), A4 (quarter note), B4 (quarter note), C5 (quarter note). Dynamic: *mp*.
- 7' 15": G4 (quarter note), A4 (quarter note), B4 (quarter note), C5 (quarter note). Dynamic: *mp*.

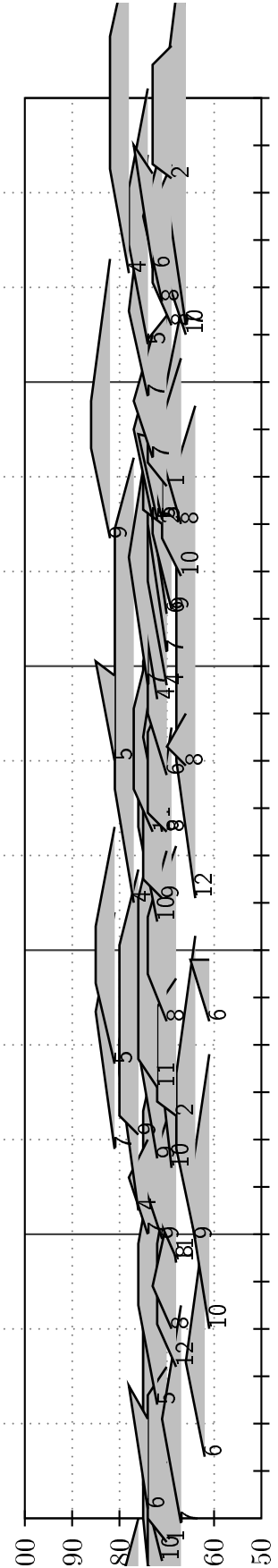

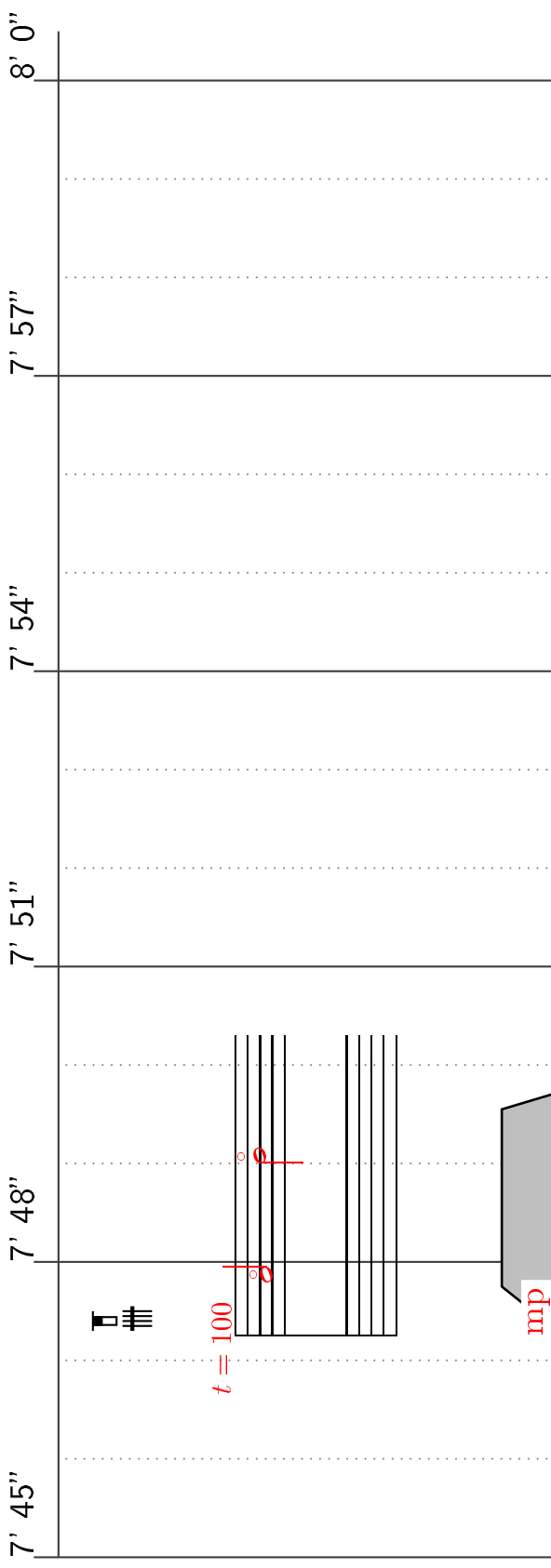

7' 45" 7' 48" 7' 51" 7' 54" 7' 57" 8' 0"

