

“KONZERT IV”

(partitur)

Piece for 4 musicians, 1 Computer and 4 Speakers

Winfried Ritsch

23.November 1999 - May 16, 2000

Notes:

All sounds should be played not too loud. The phrases should be played in blocks, like you were just producing a sound in a studio.

Each phrase has its own tempo, which means that the musician plays independent tempi. The piece is notated this way to make it easier to play the phrases with different sounds. The time where a phrase starts can be taken from a timeline. The notes are not always (but mostly) correspondent to the timeline, (because of the notation because sometimes, if tempo is very high, the notes don't fit in). There are no synchronisation points between the instruments except the stop watch.

The cents with the notes should indicate, that the pitch should be not exact the note but a little higher or lower. If some of the phrases are not playable they should be made with nearly the same sounds, even changing the notes in another octave or a quint higher or a quart lower.

The player has a stop watch which is started synchronously with all others at time 0'00".

<p>Timeline starts with 0'0" for synchronizing the stop watch</p> <p>mezzo-sopran</p>	<p>bow pressure: very strong strong middle few none</p> <p>note mode: p.gl.(first move of gliss.) gliss(glissandi)</p> <p>$t = Tempi(Quarter = \dots)$</p> <p>Clefs for Notes omitted in score </p> <p>Hallo Du</p>	<p>colors group notes to phrases with same tempo</p> <p>clef and meter for whole piece</p> <p>+30 +30</p> <p>Pitch in Cents for notes</p>	<p>Example for volume graph (cresc. - decr.), use only if possible (eg. not on pizz.,etc.)</p>	
<p>Harp</p>	<p>effect: very strong strong middle light no effect</p> <p>damp position: very high high middle low bottom</p> <p>-no damping</p> <p>$t = Tempi(Quarter = \dots)$</p> <p>Clefs for Notes omitted in score </p>	<p>colors group notes to phrases with same tempo</p> <p>clef and meter for whole piece</p>	<p>Example for volume graph (cresc. - decr.), use only if possible (eg. not on pizz.,etc.)</p>	
<p>Metal Plate</p>	<p>damping: very strong strong normal light very light without</p> <p>play mode: ric. (ricochet) ric.t(ric.tenudo) ord. (ordinare)</p> <p>play position to microphone: very far far standard near very near</p> <p>$t = Tempi(Quarter = \dots)$</p> <p>Clefs for Notes omitted in score </p>	<p>colors group notes to phrases with same tempo</p> <p>clef and meter for whole piece</p> <p>Filz Stick Wood Stick Iron Stick </p>	<p>Example for volume graph (cresc. - decr.), use only if possible (eg. not on high damping.)</p>	
<p>contrabass</p>	<p>bow pressure: strong middle crini flautato molto flautato c.leg.= col legno c.leg.s.cr.= c.leg.sensa crini</p> <p>bow position: molto sul tasto sul tasto normal sul pont molto sul pont //paralell la corda</p> <p>play mode: ric. (ricochet) ric.t(ric.tenudo) ord. (ordinare) batt(battuto) pizz(pizzicato)</p> <p>$t = Tempi(Quarter = \dots)$</p> <p>Clefs for Notes omitted in score </p>	<p>colors group notes to phrases with same tempo</p> <p>clef and meter for whole piece</p>	<p>Example for volume graph (cresc. - decr.), use only if possible (eg. not on pizz.,etc.)</p>	<p>Pitch in Cents for notes</p> <p>+30 +30</p>

Timeline starts with 0'0" for synchronizing the stop watch

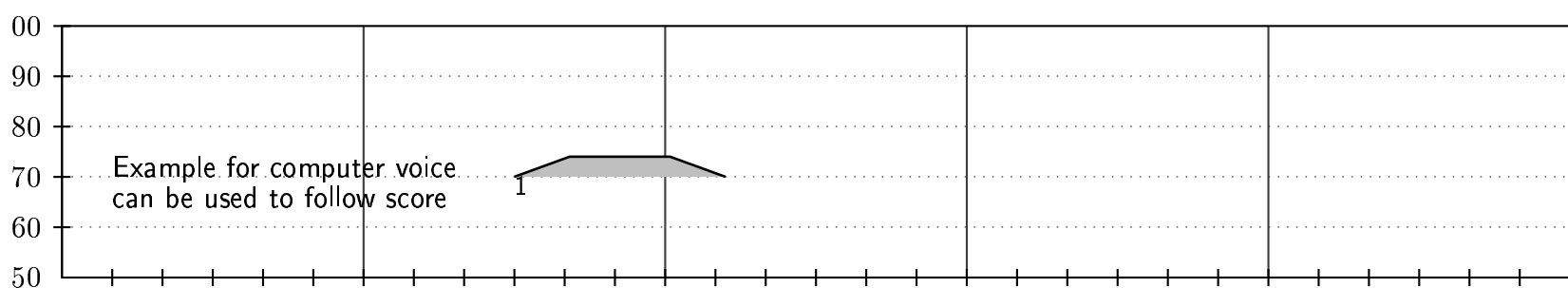

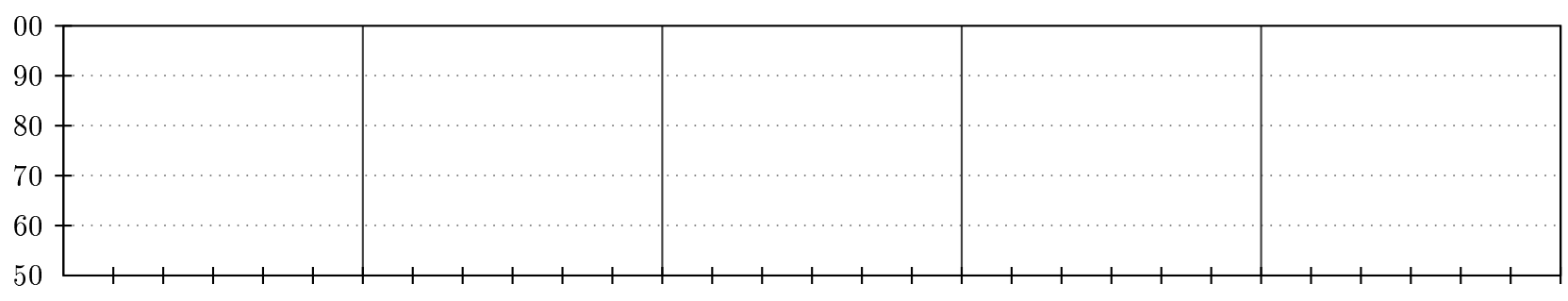
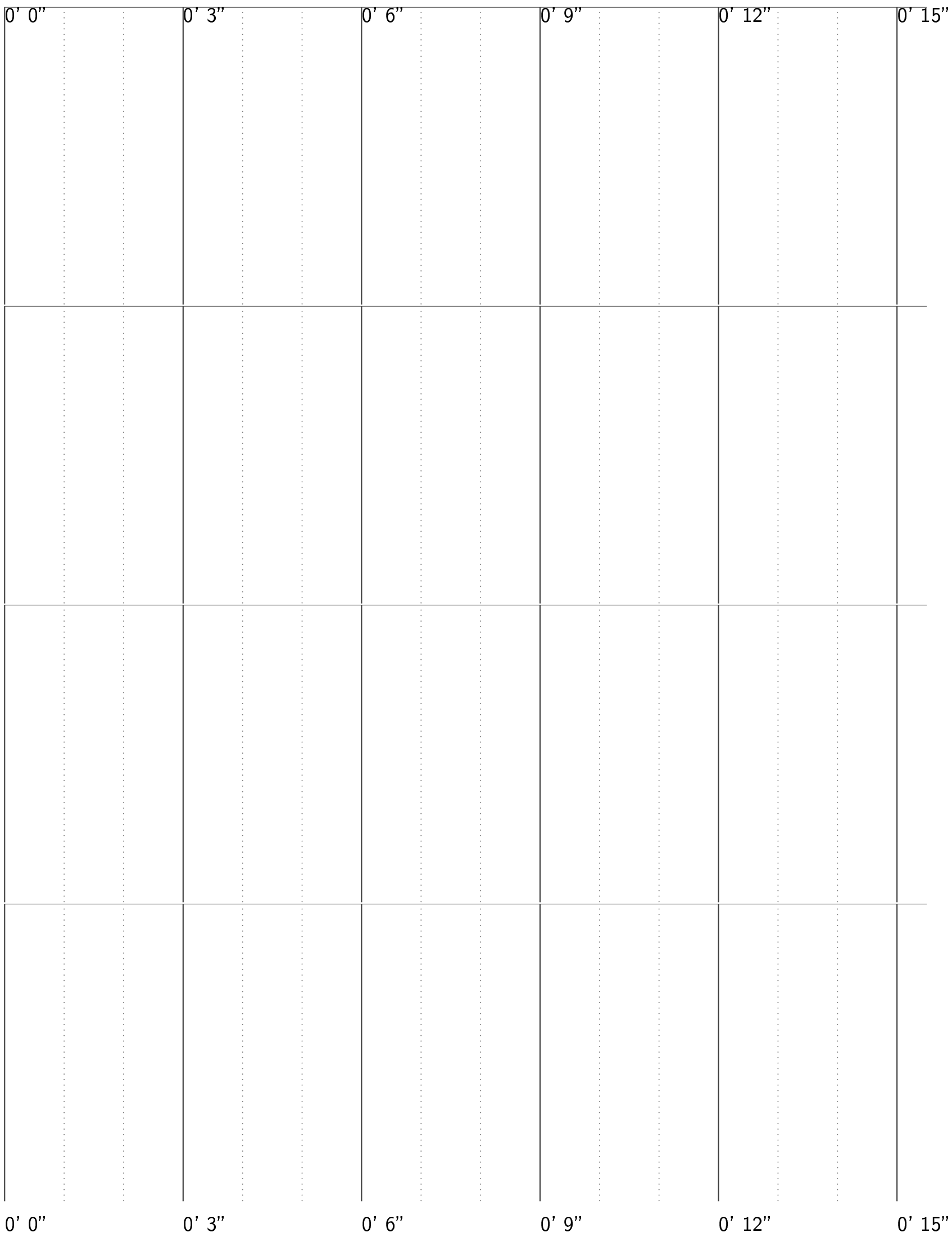

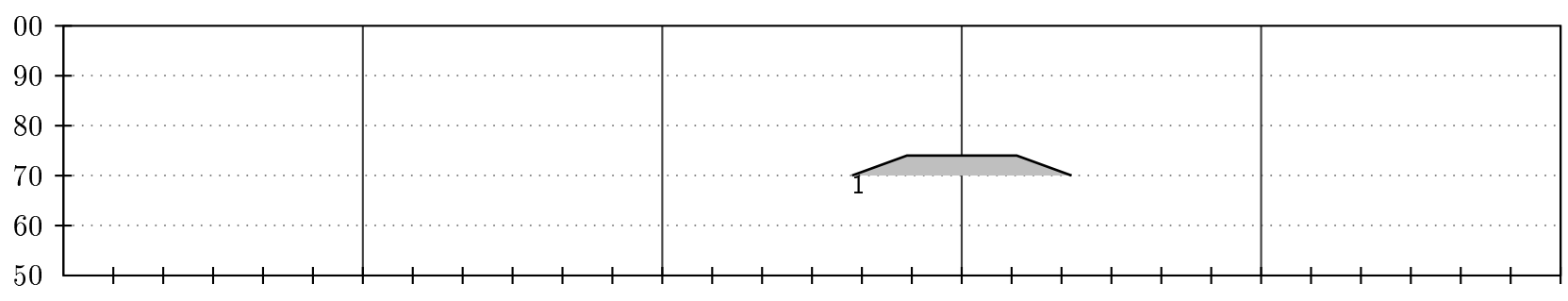
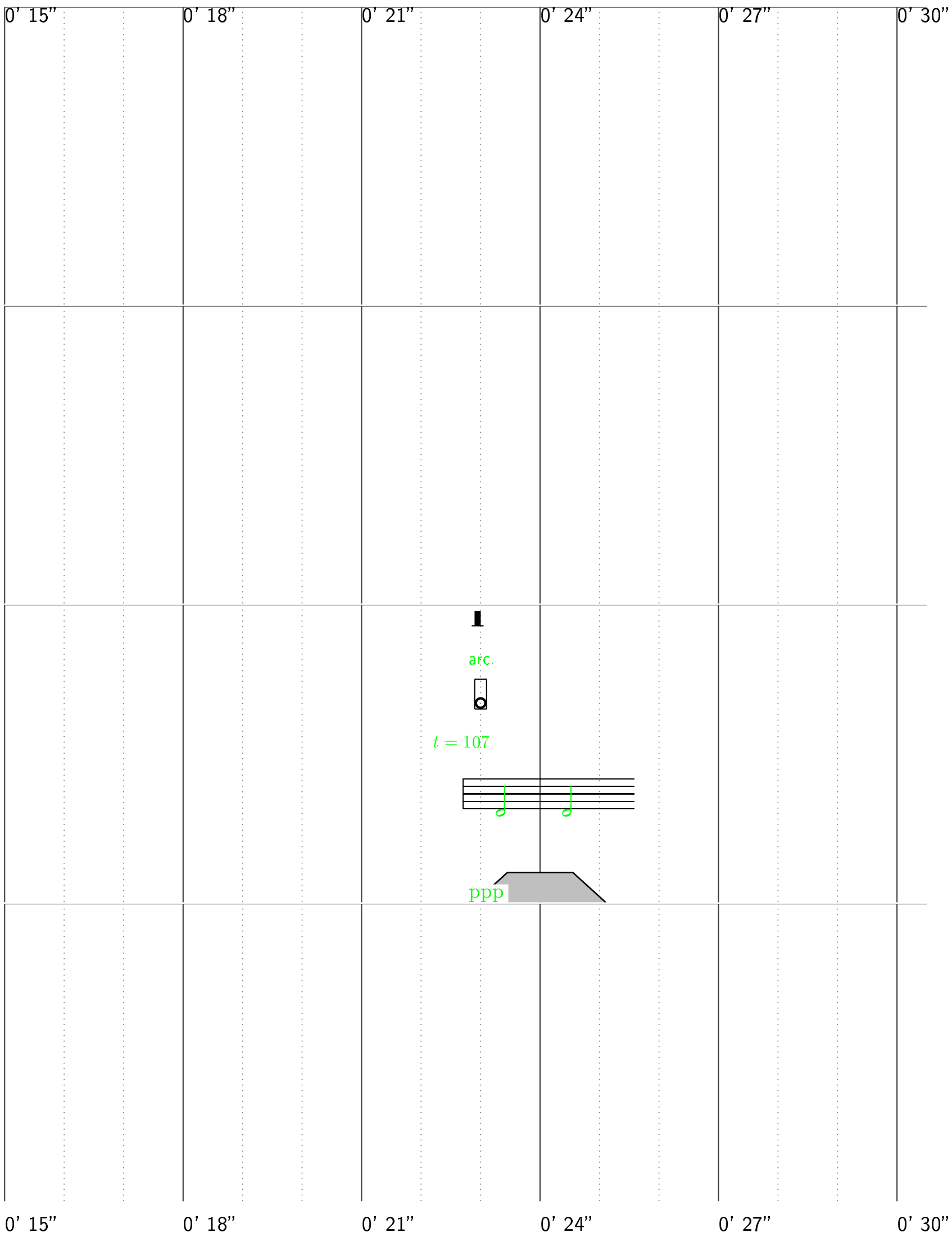

0' 30"	0' 33"	0' 36"	0' 39"	0' 42"	0' 45"
<p>arc. t = 97 ppp</p> <p>arc. t = 131 ppp</p>		<p>ord. t = 157 +30 +30 ppp</p>		<p>arc. arc. t = 111 ppp</p>	
0' 30"	0' 33"	0' 36"	0' 39"	0' 42"	0' 45"

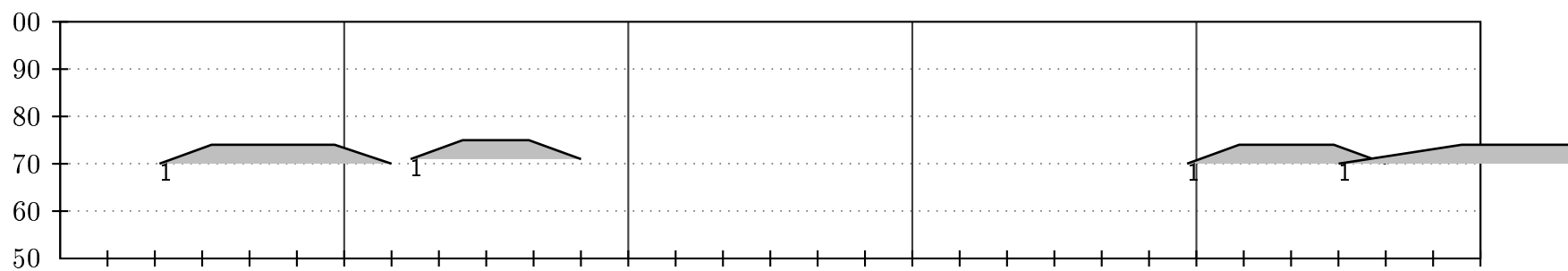

0' 45"	0' 48"	0' 51"	0' 54"	0' 57"	1' 0"

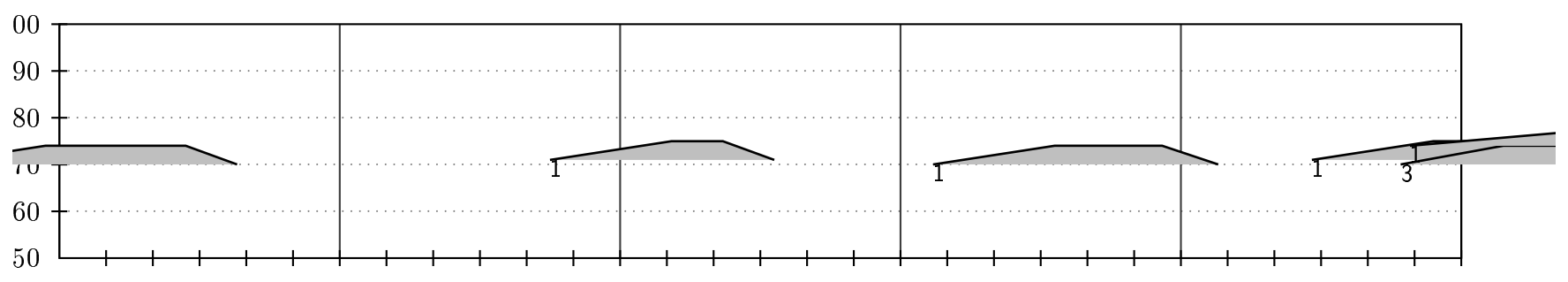

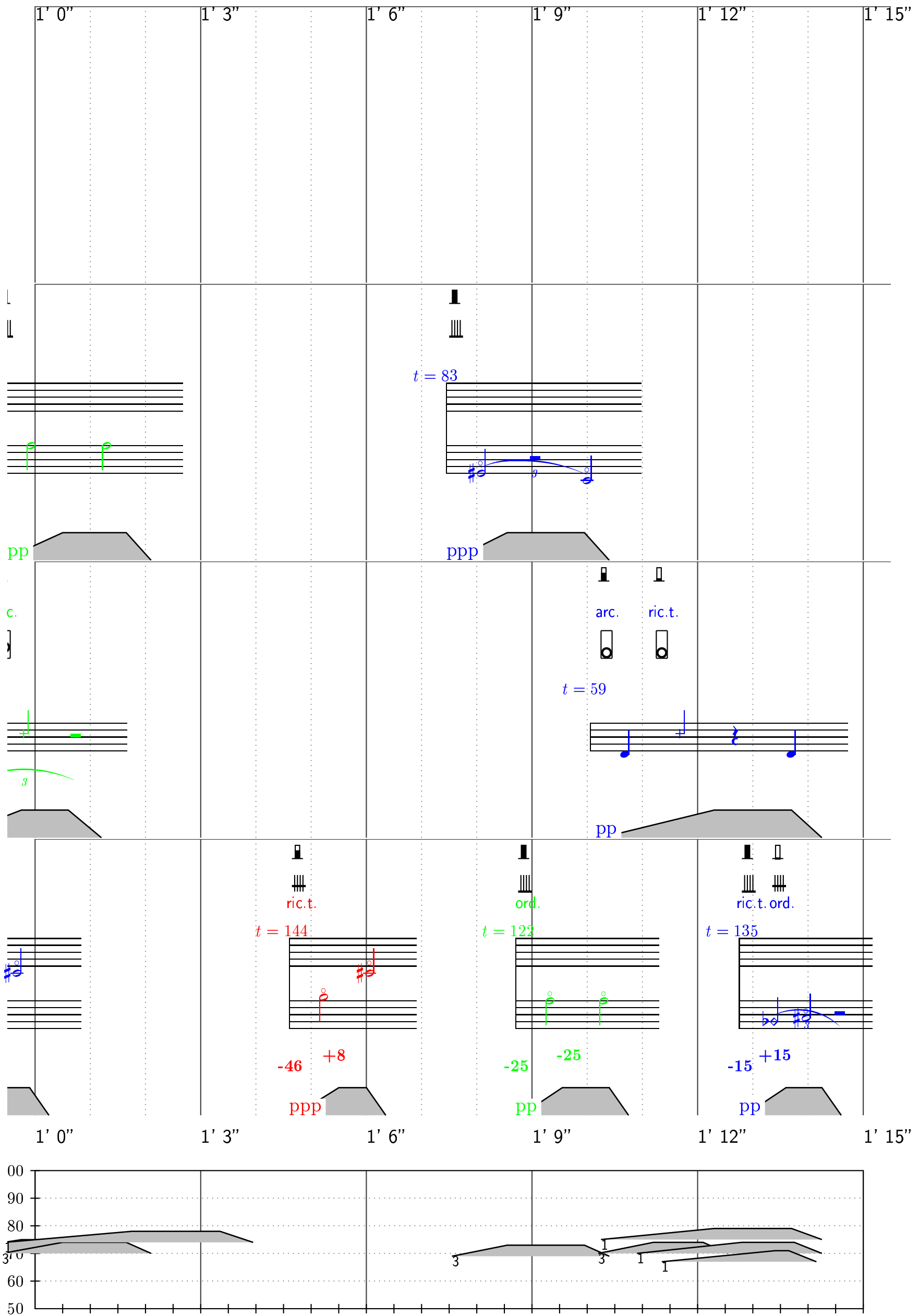

1' 15"	1' 18"	1' 21"	1' 24"	1' 27"	1' 30"
	<p><i>t = 91</i> <i>pp</i></p>		<p><i>t = 84</i> <i>pp</i></p>		
	<p><i>arc.</i> <i>t = 78</i> <i>pp</i></p>		<p><i>ric.</i> <i>t = 52</i> <i>pp</i></p>		
			<p><i>ord.</i> <i>t = 89</i> <i>-14</i> <i>+16</i> <i>pp</i></p>		
1' 15"	1' 18"	1' 21"	1' 24"	1' 27"	1' 30"

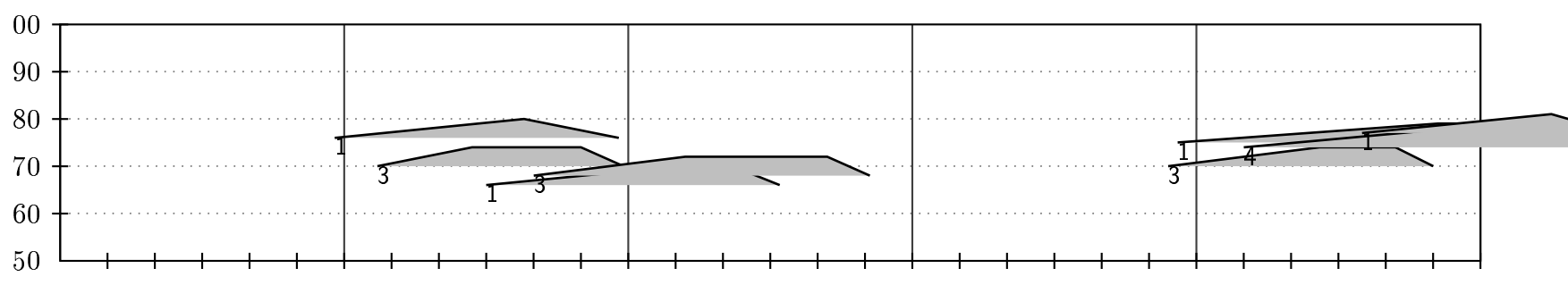

1' 30"	1' 33"	1' 36"	1' 39"	1' 42"	1' 45"
<p><i>t = 74</i></p>		<p><i>t = 79</i></p>			
<p><i>pp</i></p>		<p><i>pp</i></p>			
<p><i>arc.</i></p> <p><i>t = 61</i></p>		<p><i>ric.</i></p>		<p><i>arc.</i></p> <p><i>t = 120</i></p>	
<p><i>pp</i></p>		<p><i>pp</i></p>		<p><i>pp</i></p>	
<p><i>ord.</i></p> <p><i>t = 118</i></p> <p>+24 +49</p>		<p><i>ric.</i> <i>ric.t.</i></p> <p><i>t = 81</i></p>		<p><i>arc.</i></p> <p><i>t = 58</i></p>	
<p><i>pp</i></p>		<p>+41 -6</p> <p><i>p.gl.</i></p> <p><i>pp</i></p>		<p><i>pp</i></p>	
1' 30"	1' 33"	1' 36"	1' 39"	1' 42"	1' 45"
<p>00 90 80 70 60 50</p>					

1' 45"		1' 48"		1' 51"		1' 54"		1' 57"		2' 0"	
pp		pp		pp		pp		pp		pp	
+18		-28		+35		+44		-36		+49 -18	
pp		pp		pp		pp		pp		pp	
1' 45"		1' 48"		1' 51"		1' 54"		1' 57"		2' 0"	

2' 0" 2' 3" 2' 6" 2' 9" 2' 12" 2' 15"

t = 105

-6 -6

dah di

pp

t = 96 *t* = 115

+24 -35

tø hũ

pp pp

t = 52 *t* = 58

pp pp

arc. ric. arc.

t = 98

pp

ric.t. arc. ric.

t = 40

pp

c.t. ord. ord. ric.t.

t = 73 *t* = 100 *t* = 76

49 -18 +30 +30 +14 +4 +9 -37

pp pp pp

2' 0" 2' 3" 2' 6" 2' 9" 2' 12" 2' 15"

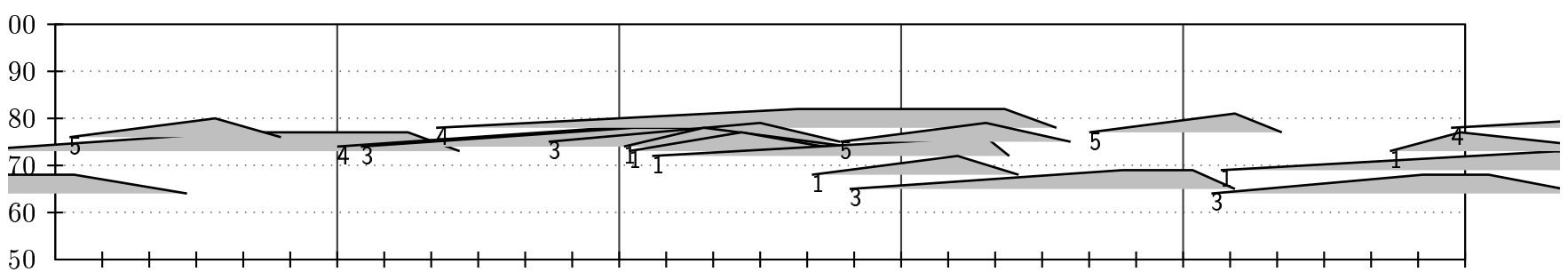

2' 15"	2' 18"	2' 21"	2' 24"	2' 27"	2' 30"
	<p><i>t = 112</i></p> <p><i>fi wu di</i></p> <p>pp</p>			<p><i>t = 103</i></p> <p><i>dah fū</i></p> <p>pp</p>	
	<p><i>t = 100</i></p> <p>pp</p>	<p><i>t = 60</i></p> <p>pp</p>		<p><i>t = 110</i></p> <p>pp</p>	
<p>ric.</p> <p>pp</p>				<p>ric. arc.</p> <p>pp</p>	<p>ric.t. arc.</p> <p>pp</p>
		<p><i>c. leg. s. cr.</i></p> <p><i>ordric.</i></p> <p><i>t = 147</i></p> <p><i>t = 166</i></p> <p>pp</p>		<p><i>ric.t.</i></p> <p><i>t = 66</i></p> <p>pp</p>	
2' 15"	2' 18"	2' 21"	2' 24"	2' 27"	2' 30"

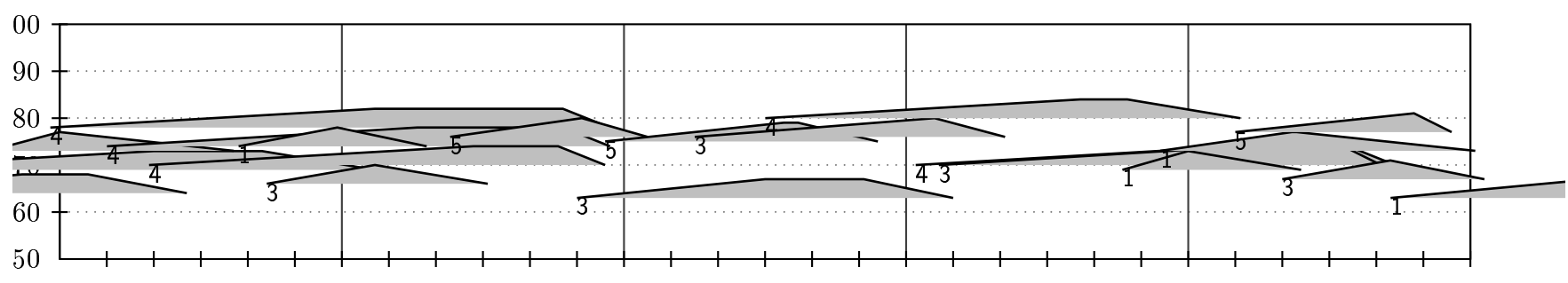

2' 30"	2' 33"	2' 36"	2' 39"	2' 42"	2' 45"
<i>t = 89</i> #2 #2 +39 -7 lu ti pp	<i>t = 96</i> #2 #2 +49 -19 fi fu pp				
	<i>t = 53</i> - - - pp			<i>t = 88</i> #2 #2 - - - pp	
t. arc.	ric.t.	arc.	ric.	ric.t.	arc.
	<i>t = 97</i>	<i>t = 148</i>	<i>t = 98</i>	<i>t = 56</i>	
3	pp	pp	pp	pp	
c.leg.s.cr. // ric.			c.leg.s.cr. // ric.ord.	ric.t.	
<i>t = 176</i>			<i>t = 91</i>	<i>t = 137</i>	
9	-14 -14		-11 -10 +3 p.gl.	-43 -25	
pp	pp		pp	pp	
2' 30"	2' 33"	2' 36"	2' 39"	2' 42"	2' 45"

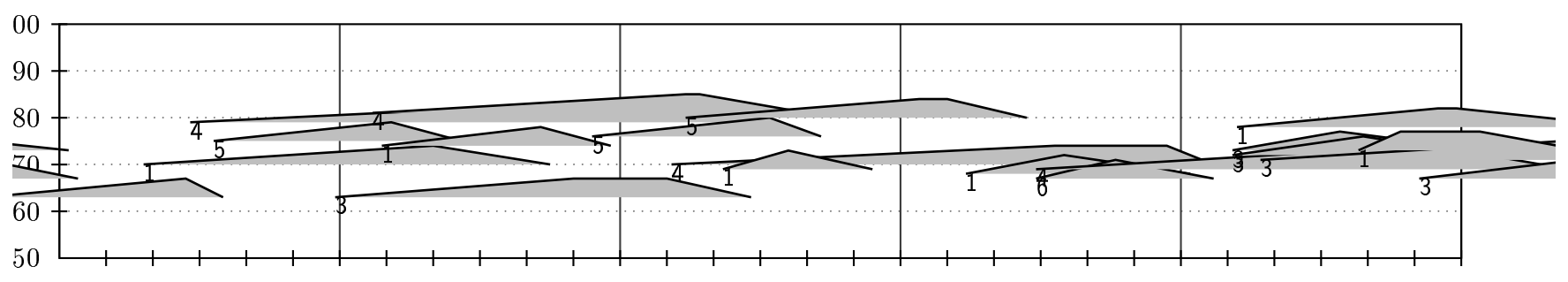

Musical score with multiple staves and time markers. The score is organized into columns corresponding to time points: 2' 45", 2' 48", 2' 51", 2' 54", 2' 57", and 3' 0".

Staff 1 (Top): Contains vocal lines with lyrics. Time markers include $t = 69$ and $t = 84$. Lyrics include "qi tî zø" and "fî".

Staff 2: Contains piano accompaniment. Time marker $t = 44$ is present.

Staff 3: Contains performance instructions such as "ric.t.", "arc.", "ric.tarc.", and "ric.t.". Time markers include $t = 89$, $t = 112$, and $t = 94$.

Staff 4: Contains performance instructions such as "ric.t.", "ord.", "ric.", and "ord.". Time markers include $t = 143$, $t = 103$, $t = 144$, and $t = 85$.

Staff 5 (Bottom): A performance graph showing dynamics and articulation. The vertical axis is labeled from 50 to 00. The graph shows various peaks and troughs with numerical annotations (e.g., 5, 4, 3, 6, 1, 1, 4, 5, 1, 6) indicating specific performance parameters.

Lyrics and Annotations:

- Blue lyrics: "qi tî zø" (at $t = 69$), "ord." (at $t = 103$).
- Red lyrics: "fî" (at $t = 84$), "ric.t." (at $t = 89$), "ric." (at $t = 144$).
- Green lyrics: "ric.t." (at $t = 143$), "ord." (at $t = 85$).

Dynamic and Performance Markings:

- pp (pianissimo) is used in several places.
- Articulation marks include "ric.t.", "arc.", "ric.tarc.", and "ord.".
- Accents and slurs are present on various notes.

3' 0"	3' 3"	3' 6"	3' 9"	3' 12"	3' 15"
	<p>p.gl. t = 63</p> <p>+6 tũ</p> <p>+31 zũ</p> <p>pp</p>		<p>p.gl. t = 69</p> <p>-18 hah</p> <p>-28 fæ</p> <p>+0 ræ</p> <p>-46 wũ</p> <p>pp</p>		
	<p>t = 104</p> <p>t = 81</p> <p>pp</p>		<p>t = 85</p> <p>t = 113</p> <p>pp</p>		
	<p>arc. arc. t = 72</p> <p>pp</p>	<p>arc. arc. ric. t. t = 126</p> <p>pp</p>	<p>arc. t = 93</p> <p>pp</p>	<p>ric. ric. t. t = 113</p> <p>pp</p>	
	<p>ric. t. t = 138</p> <p>-27 -37</p> <p>pp</p>	<p>ondc. t. ord. t = 168</p> <p>+14 +49-44 -32</p> <p>pp</p>	<p>ric. t. t = 147</p> <p>+47</p> <p>pp</p>	<p>ord. t = 109</p> <p>+18 +</p> <p>pp</p>	
3' 0"	3' 3"	3' 6"	3' 9"	3' 12"	3' 15"

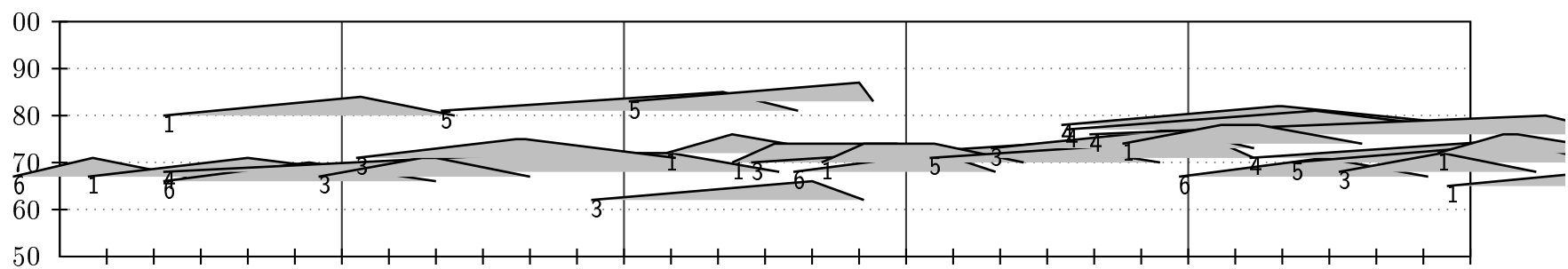

3' 15" 3' 18" 3' 21" 3' 24" 3' 27" 3' 30"

t = 114 *t* = 73 *t* = 62

-46 *w*ü *d*ø *t*æ *l*ø *f*i *f*u *l*u

pp pp pp pp

t = 86 *t* = 60 *t* = 85

pp pp pp pp

ric. ric.t. m.ric. m.ric. ric.t. arc. arc.

113 *t* = 113 *t* = 113 *t* = 88 *t* = 143

pp pp pp pp pp

ord. ordord. ric.t. ord. ric.

= 109 *t* = 94 *t* = 164 *t* = 144 *t* = 90

+18 +32 -30 -41 +18 +18 +11 -1 +17

pp pp pp pp pp

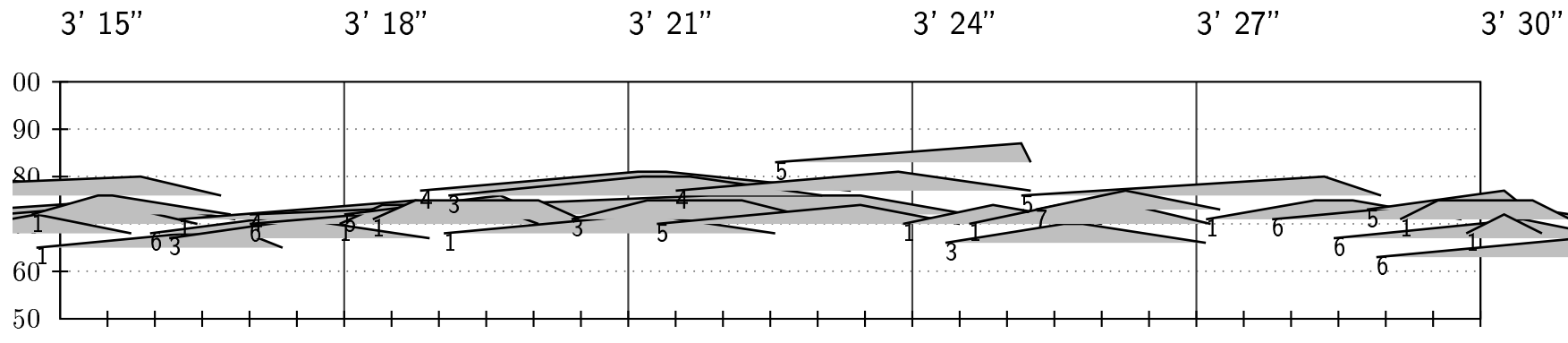

3' 30"	3' 33"	3' 36"	3' 39"	3' 42"	3' 45"
	$t = 65$ -25 fah -25 li			$t = 108$ -19 zulu -19 +3 i +41 fi	
	$t = 104$	$t = 93$	$t = 74$	$t = 110$	
pp	pp	pp	pp	8va pp	
arc.	ric.t.	arc.	ric.	ric.	ric.t. arc. ric.
= 143	$t = 85$		$t = 114$ $t = 76$	$t = 68$	
pp	pp	pp	pp	pp	pp
ord. batt. ord.	ric.	battord.	ric.t.	ordord.	
$t = 94$	$t = 106$	$t = 173$	$t = 137$	$t = 94$	
+17 +29 +30 -19 +4 l. p.gl.	+22 +12	+30 -27 +48 p.gl.	+44 +44 -49 -27		
pp	p	pp	pp	pp	pp
3' 30"	3' 33"	3' 36"	3' 39"	3' 42"	3' 45"

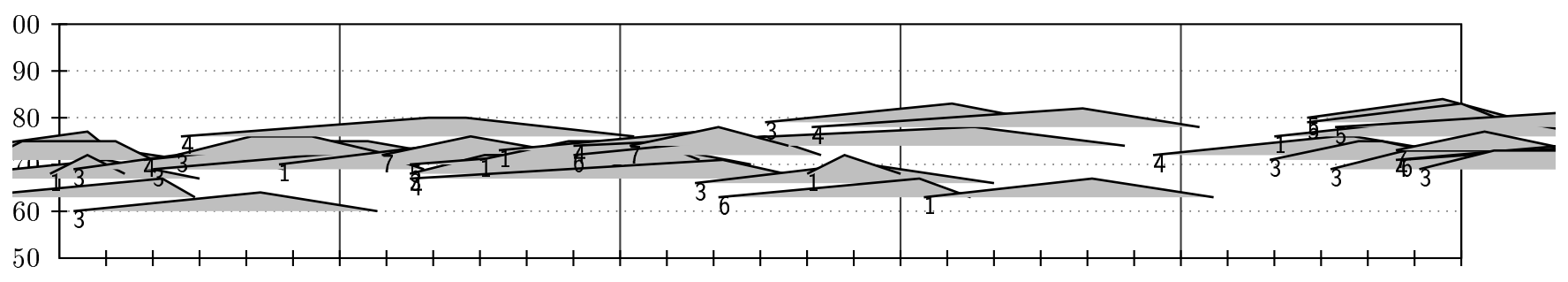

3' 45" 3' 48" 3' 51" 3' 54" 3' 57" 4' 0"

t = 54 *t* = 118

+41
fi

-14 +10
lu zi

-48 -48
i wu

p

t = 89 *t* = 102 *t* = 102

pp *pp* *pp*

ric. ric. ric. m. ric. arc. ric. ric.

t = 164 *t* = 99 *t* = 83

pp *pp* *pp*

ric.t. ord. c. leg. s. cr. ric. ric. ric.t.

t = 127 *t* = 148 *t* = 154 *t* = 116 *t* = 104

+0 -15 +10 +2-8 -6 +48 -44
p.gl. p.gl. p.gl. p.gl. p.gl.

pp *pp* *pp* *pp* *pp*

3' 45" 3' 48" 3' 51" 3' 54" 3' 57" 4' 0"

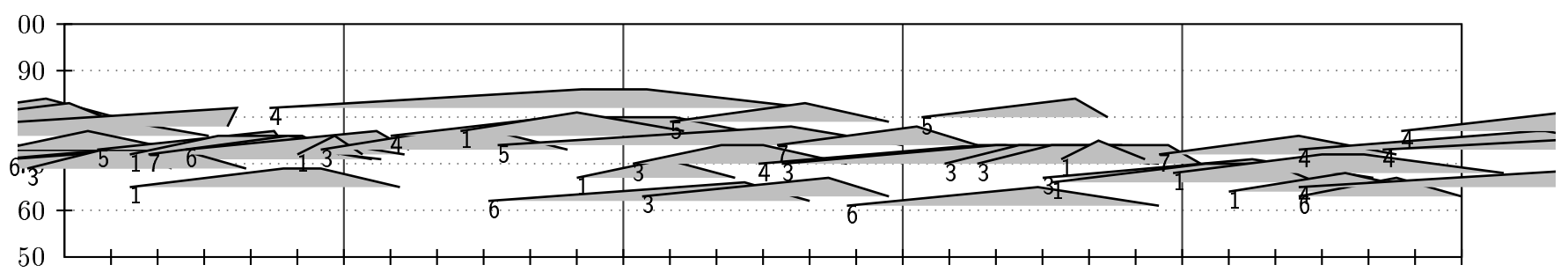

4' 0"	4' 3"	4' 6"	4' 9"	4' 12"	4' 15"
	p.gl. t = 125	t = 97		t = 101	t = 136
	-47 li	+23 zu +41 ah		+7 wah +7 ah	+24 li +14 dah
	pp	p		p	pp
t = 103	t = 86		t = 80		t = 156
8va pp	pp		p		pp
m.ric. arc.		arc.ric.t. ric.t.	arc. arc.		
t = 159 = 94		t = 94	t = 119		
pp	pp	pp	pp		
ord. c.leg.s.cr. ric. //	c.leg.leg. ric. batt.		ord.ric. ord. ric.		
= 163 t = 107	t = 154		t = 130 t = 167		
+6 p.gl. +20 p.gl. +11 p.gl. -35 p.gl.	+2 gliss. +47 gliss. +27 gliss.		-27 p.gl. +41 p.gl. -8 p.gl. -43 p.gl. +11 p.gl.		
pp	pp		p	pp	
4' 0"	4' 3"	4' 6"	4' 9"	4' 12"	4' 15"

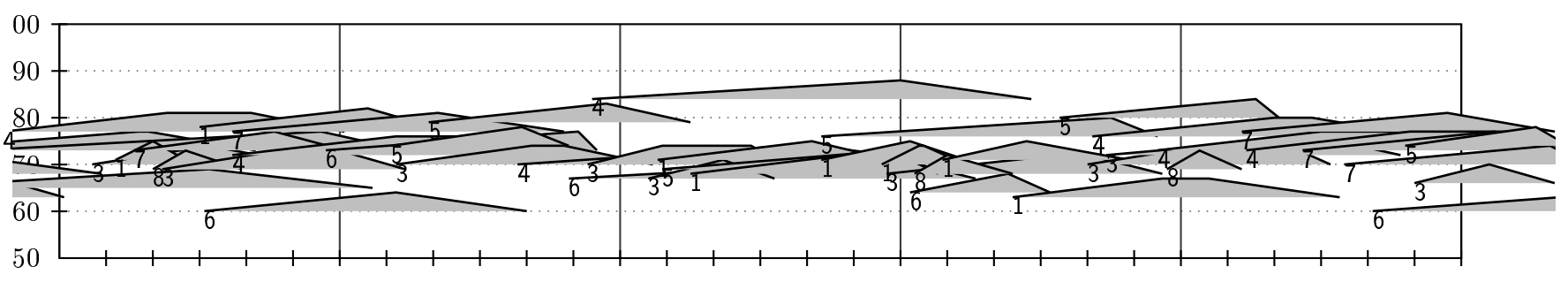

4' 15" 4' 18" 4' 21" 4' 24" 4' 27" 4' 30"

36 *p.gl.*
t = 104 *t = 68* *t = 98*

24 +14 +8 -33 -8 +37 +27
 li dah fø hah ki ø ah

pp pp p p

56 *t = 68* *t = 92* *t = 91*

pp pp pp p

ric.t. *arc.* *arc.* *ric. ric.* *ric.* *arc.*

t = 141 *t = 69* *t = 115* *t = 141* *t = 102*

pp p pp p pp

c.leg. *c.leg.*
batt. *ord.* *ord.* *ordic.t.* *ord.ord.* *ric.t.*

= 102 *t = 142* *t = 141* *t = 110* *t = 175* *t = 103*

+0 -35
gliss. *p.gl.*

pp pp pp pp pp pp pp

4' 15" 4' 18" 4' 21" 4' 24" 4' 27" 4' 30"

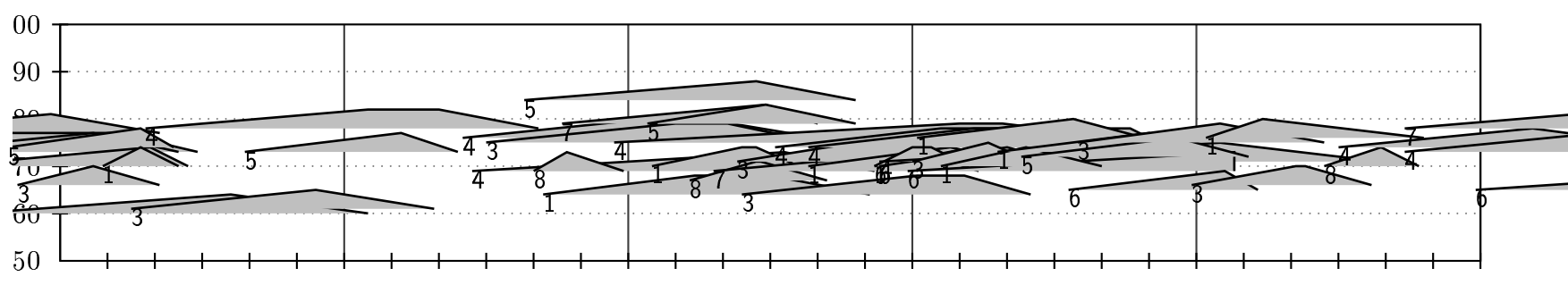

4' 30"	4' 33"	4' 36"	4' 39"	4' 42"	4' 45"
<p>$t = 128$</p> <p>-21 +14 dǎh tzu</p> <p>p</p>	<p>$t = 116$</p> <p>+12 +12 i a</p> <p>p</p>	<p>$t = 91$</p> <p>-18 -25 lu tzu</p> <p>p</p>	<p>$t = 136$</p> <p>+35 +24 -35 kalǎe qi</p> <p>pp</p>		
	<p>$t = 89$</p> <p>p</p>	<p>$t = 101$</p> <p>pp</p>		<p>$t = 95$</p> <p>p</p>	
<p>ric.</p> <p>$t = 79$</p> <p>p</p>	<p>m. ric.</p> <p>$t = 159$</p> <p>pp</p>	<p>m. ric.</p> <p>$t = 105$</p> <p>pp</p>	<p>arc.</p> <p>$t = 122$</p> <p>p</p>		
<p>ric.t.</p> <p>$t = 103$</p> <p>-21 pp</p>	<p>ord.</p> <p>$t = 117$</p> <p>-36 -11 p</p>	<p>ord. ric. tic.</p> <p>$t = 161$</p> <p>+8 -15 +30 -2 p gl. p</p>	<p>ric.</p> <p>$t = 116$</p> <p>-33 +21 p gl. p</p>	<p>ord.</p> <p>$t = 164$</p> <p>-28 -28 p gl. p</p>	
4' 30"	4' 33"	4' 36"	4' 39"	4' 42"	4' 45"

4' 45" 4' 48" 4' 51" 4' 54" 4' 57" 5' 0"

4 -35
læ qi

t = 111 -23
tzæ

t = 126 -35 -6 -45
i lø gø

t = 127 -6 +46 +24
qî qø qah

p p pp p

t = 112

t = 95

t = 74

p pp p

ric.t.

arc. ric.t.

arc.

ric.

t = 153 t = 128 t = 104 t = 165

pp p pp p

ric.

batt. ric.

batt. battrd.

t = 121 t = 114 t = 162 t = 158 t = 122

-14 -24

-47 +7 -14

+33 +6 +2

p.p.g.l. p.p.g.l. p.p.g.l. p.p.g.l.

pp p p p

4' 45" 4' 48" 4' 51" 4' 54" 4' 57" 5' 0"

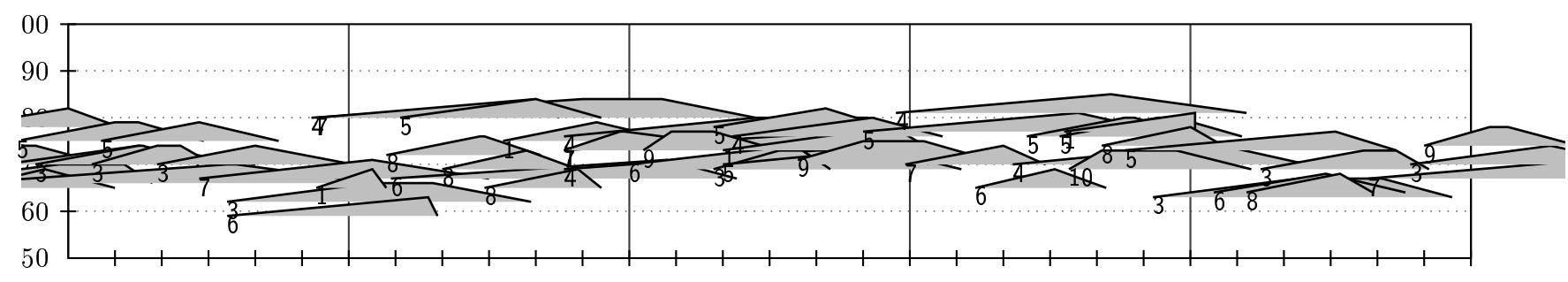

5' 0"	5' 3"	5' 6"	5' 9"	5' 12"	5' 15"
<p>p.gl.</p> <p>t = 122</p> <p>-6 +38 +19</p> <p>nø qø ah</p> <p>p</p>	<p>t = 102</p> <p>+10 +24 +37</p> <p>qu qî lî</p> <p>p</p>	<p>t = 102</p> <p>+10 +24 +37</p> <p>qu qî lî</p> <p>p</p>	<p>p.gl. p.gl.</p> <p>t = 95</p> <p>-35 +49 +3 +40</p> <p>qî î zæ ou</p> <p>p</p>		
<p>= 170</p> <p>pp</p>	<p>t = 98</p> <p>p</p>	<p>t = 76</p> <p>p</p>	<p>t = 127</p> <p>p</p>		
<p>ric.t. arc.</p> <p>t = 102</p> <p>p</p>	<p>m.ric.</p> <p>t = 172</p> <p>pp</p>	<p>arc. ric.</p> <p>t = 149</p> <p>pp</p>	<p>m.rîrc.</p> <p>t = 107</p> <p>p</p>		
<p>ric.t.</p> <p>t = 101</p> <p>-13 -13</p> <p>p</p>	<p>ord.</p> <p>t = 94</p> <p>-44 -30</p> <p>p</p>	<p>ord.</p> <p>t = 156</p> <p>-36</p> <p>p</p>	<p>ric.</p> <p>t = 119</p> <p>-6 -6</p> <p>p.gl.</p> <p>p</p>		
5' 0"	5' 3"	5' 6"	5' 9"	5' 12"	5' 15"

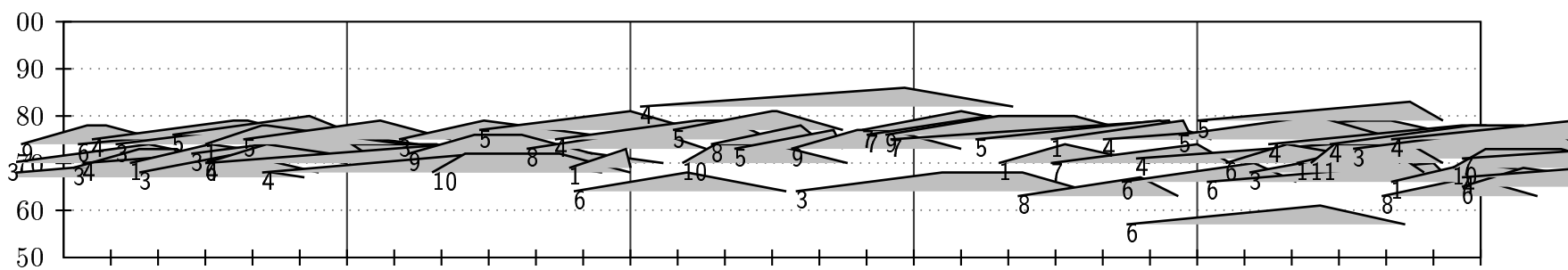

5' 15"	5' 18"	5' 21"	5' 24"	5' 27"	5' 30"
<p>p.g.b.gl.</p> <p>t = 90</p> <p>-33 -41 -19</p> <p>kî kævou</p> <p>p</p>	<p>p.gl. p.gl.</p> <p>t = 78</p> <p>+22 -29 +26</p> <p>i zî u</p> <p>p</p>	<p>p.gl. gliss. gliss.</p> <p>t = 109 t = 105</p> <p>-23 -23 -33 +12</p> <p>kî vu tzoula</p> <p>p p</p>	<p>ric.t. ord.</p> <p>t = 144</p> <p>+0 -34 +14</p> <p>p</p>	<p>batt.</p> <p>t = 107</p> <p>+26 -20</p> <p>p.gl. p</p>	<p>ordric. batt. ord.</p> <p>t = 102 t = 145 t = 139</p> <p>+30 -28 -41 +49 -39</p> <p>p.gl. p p</p>
5' 15"	5' 18"	5' 21"	5' 24"	5' 27"	5' 30"

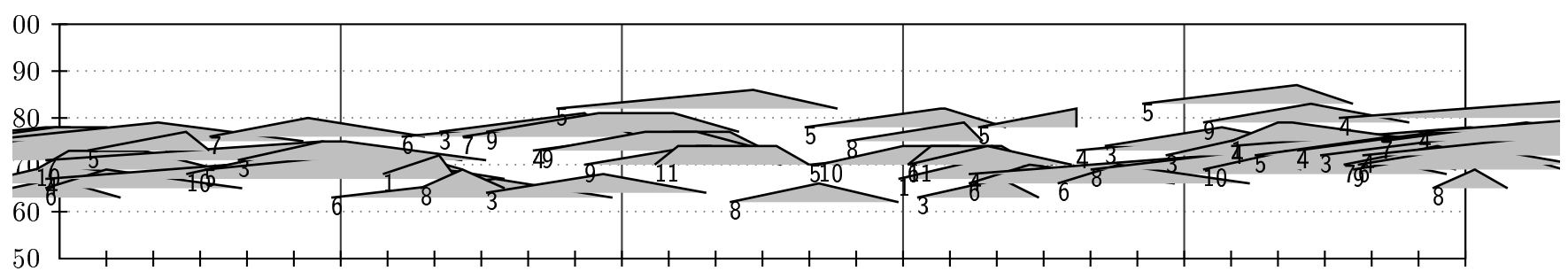

5' 30"	5' 33"	5' 36"	5' 39"	5' 42"	5' 45"
	p.gl. t = 90 +37 zu	p.gl. t = 122 -35 -10 î î	gliss. t = 110 +24 -41 gahu	p.gl. t = 110 +14 lî	
	p	p	p	p	
	t = 127	t = 88	t = 105		
	p	8va p	p	p	
m.ric. t = 112	m.ric. t = 143	t = 97	ord. t = 104	ric.t. t = 120	
p	p	p	p	p	
	c.leg. batt. t = 99 +14 gliss. p	t = 139 -27 gliss. p	ric. t = 160 +27 -19 p.gl. p		
5' 30"	5' 33"	5' 36"	5' 39"	5' 42"	5' 45"

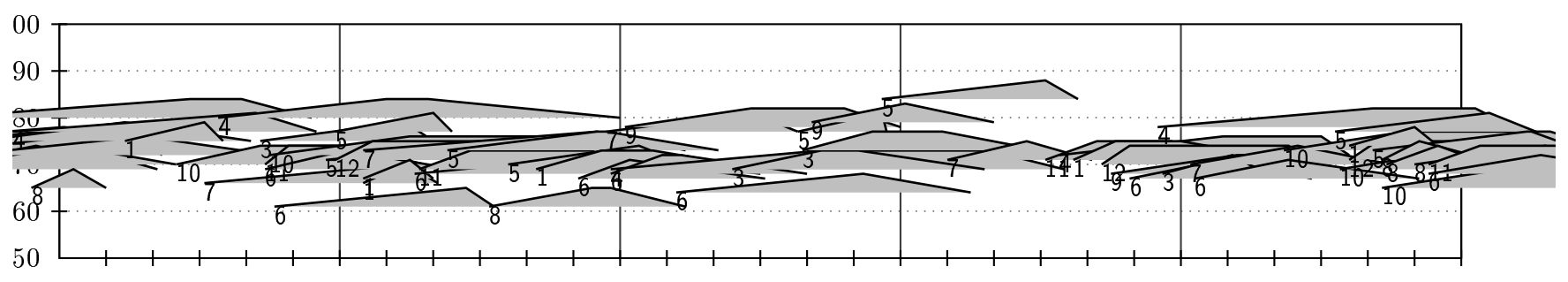

5' 45" 5' 48" 5' 51" 5' 54" 5' 57" 6' 0"

gl. $t = 103$ $t = 76$ $t = 111$ $t = 77$

hu +14 -6 +40 +12 +18 $t = 114$ $t = 156$ $t = 98$
 li u i li hu vi vu za ou æ

p mp p mp

$t = 114$ $t = 156$ $t = 98$

p p p

arc. ric. arc. arc. $t = 100$ $t = 106$

p p

batt. $t = 163$ $t = 176$ $t = 136$ pizz. $t = 144$ $t = 155$ ric.t.

-2 +32-46 -6 +48 -11 -11 -14-24
 p.gl. p.gl. gliss. gliss. p

5' 45" 5' 48" 5' 51" 5' 54" 5' 57" 6' 0"

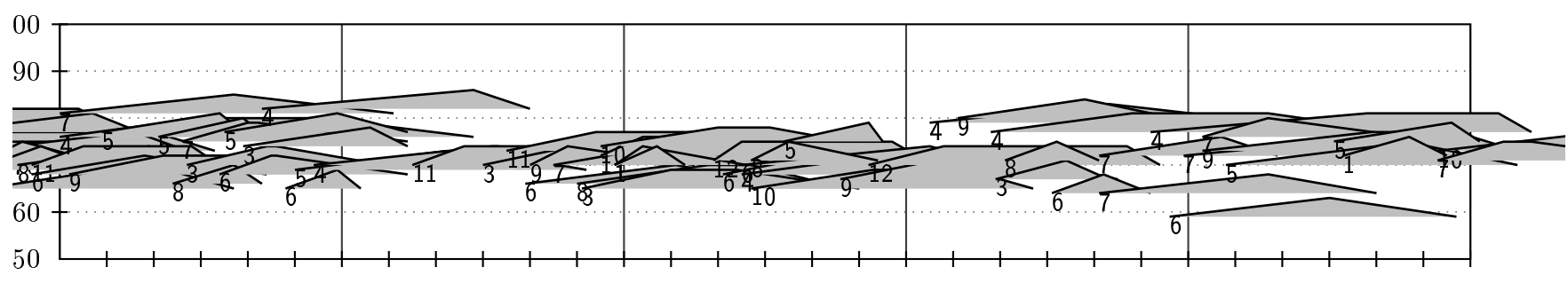

6' 0"	6' 3"	6' 6"	6' 9"	6' 12"	6' 15"
<p>p.gl.</p> <p>t = 94</p> <p>-40 -37 -28 +49</p> <p>u æ lalohæ</p> <p>p</p>	<p>p.gl.</p> <p>t = 94</p> <p>+38 +28</p> <p>vî fu</p> <p>p</p>	<p>t = 76</p> <p>-49 +5</p> <p>la hî</p> <p>mp</p>	<p>p.gl. p.gl.</p> <p>t = 141</p> <p>+18 -49</p> <p>fæ fu</p> <p>p</p>		
<p>t = 78</p> <p>mp</p>	<p>t = 87</p> <p>p</p>	<p>t = 163</p> <p>p</p>	<p>t = 170</p> <p>p</p>	<p>t = 81</p> <p>mp</p>	
<p>arc. arc.</p> <p>t = 99</p> <p>p</p>		<p>arc.</p> <p>t = 170</p> <p>p</p>		<p>arc.</p> <p>t = 150</p> <p>p</p>	
		<p>c.leg.leg.</p> <p>ordric.</p> <p>t = 138</p> <p>-1 +30</p> <p>p.gb.gl.</p> <p>p</p>		<p>ord.</p> <p>t = 137</p> <p>-36 -36</p> <p>p</p>	
6' 0"	6' 3"	6' 6"	6' 9"	6' 12"	6' 15"

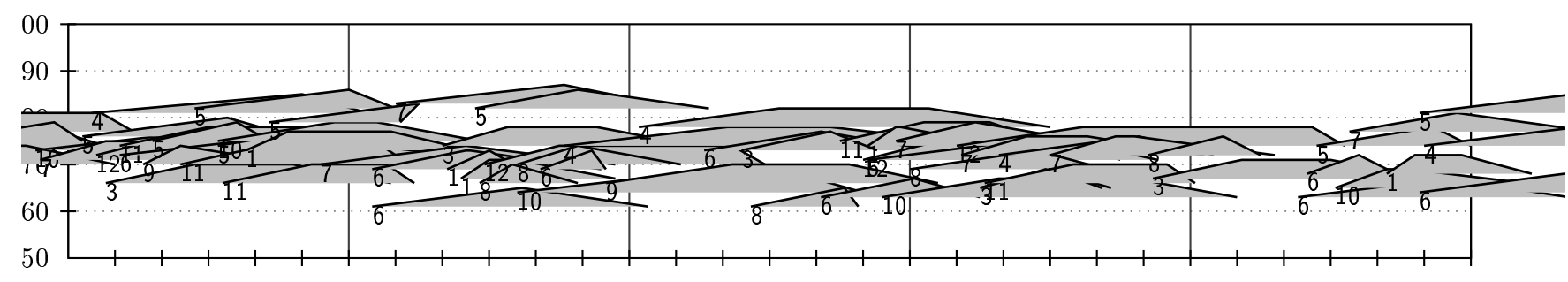

6' 15" 6' 18" 6' 21" 6' 24" 6' 27" 6' 30"

p.g.l.
t = 87
 -2 qî -12 u
p

t = 108 *t = 116* *t = 102*
 -48 fi +22 u +10 lø +29 ah +19 u
p *mp* *p*

t = 80
p

t = 81
p

ric.t.
t = 120
p

arc. arc.
t = 154
p

arc.
t = 154
p

ord. *ord.*
t = 136 *t = 172*
 +21 -41-23
p *p*

ord.
t = 110
 -32 -32
p

ord.
t = 99
 +2 -8
p

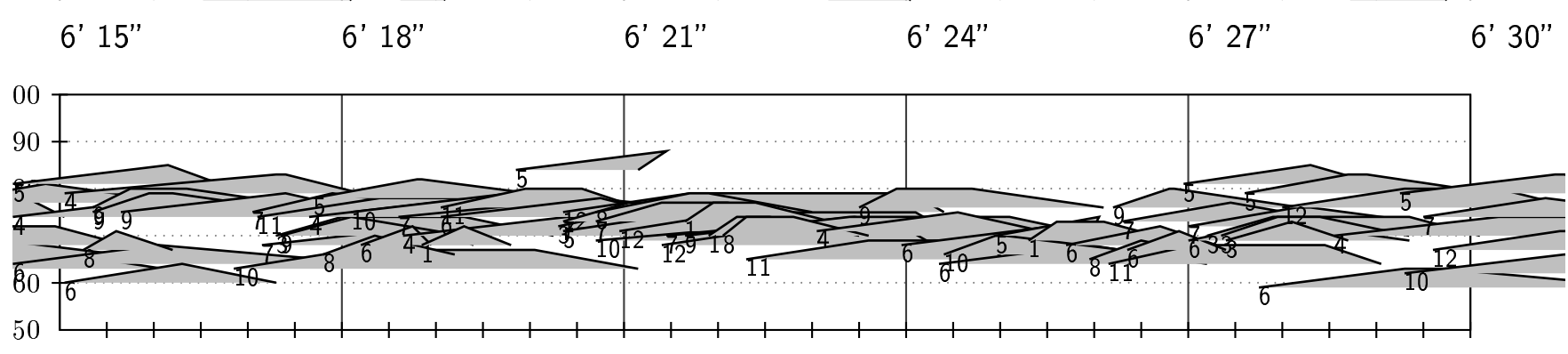

6' 30"	6' 33"	6' 36"	6' 39"	6' 42"	6' 45"
2 ah u +19	p.gl. wø -40 mp	t = 85 tæ qũ -35 -10 mp	p.gl. î î -10 -20 p		
	t = 139 mp	t = 81 p			
arc. t = 146 p	ric.t. t = 135 p	arc. t = 165 p	arc. t = 145 mp		
	ric.t. t = 147 +38 p	ord. t = 100 -44 -19 p	ord. t = 103 +24 +14 p.g.l. p		
6' 30"	6' 33"	6' 36"	6' 39"	6' 42"	6' 45"

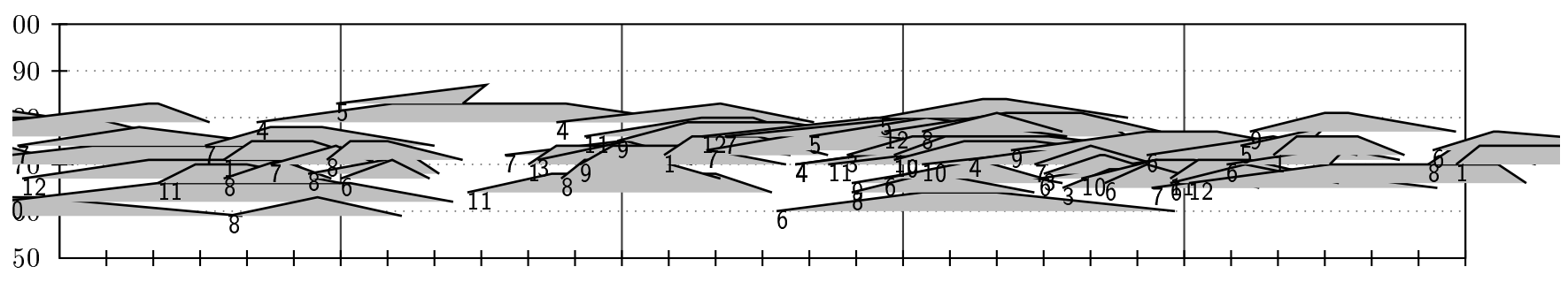

6' 45"	6' 48"	6' 51"	6' 54"	6' 57"	7' 0"
<p>p.gl.</p> <p>t = 133</p> <p>-6 +38 +12</p> <p>ø lū nø</p> <p>p</p>	<p>p.gb.gl.</p> <p>t = 113</p> <p>+24 +25 +49</p> <p>qîqu</p> <p>mp</p>	<p>gliss.</p> <p>t = 130</p> <p>-21 -31</p> <p>i hî</p> <p>mp</p>			
<p>= 120</p> <p>mp</p>	<p>t = 109</p> <p>mp</p>	<p>t = 161</p> <p>p</p>	<p>t = 116</p> <p>mp</p>		
<p>arc.</p> <p>= 145</p> <p>mp</p>	<p>ric.</p> <p>t = 122</p> <p>p</p>	<p>ric.t.</p> <p>t = 150</p> <p>mp</p>	<p>arc</p> <p>t = 126</p> <p>mp</p>		
<p>ord.</p> <p>t = 98</p> <p>+41 -5</p> <p>mp</p>	<p>ric.t.</p> <p>t = 91</p> <p>+18 +18</p> <p>mp</p>	<p>ord.</p> <p>t = 91</p> <p>+35 +25</p> <p>p</p>	<p>ord.</p> <p>t = 106</p> <p>-38 +16</p> <p>mp</p>	<p>ord.</p> <p>t = 94</p> <p>+30</p> <p>mp</p>	
6' 45"	6' 48"	6' 51"	6' 54"	6' 57"	7' 0"

7' 0" 7' 3" 7' 6" 7' 9" 7' 12" 7' 15"

gliss. t = 84
+37 -9
lu nu

p.gl. t = 94
-8
wø

p.gl. t = 113
-37
qî

p.g.gl. t = 126 t = 88
-4 -43
fuî

gliss. t = 88
-41 -41
nø rø

mp mp mp mp mp

t = 111
mp

t = 111 t = 105
mp mp

arc. 126
mp

arc. t = 131
mp

d. t = 162
-4 p.gl.
mp

ric.t. t = 97
-49 +5
mp

ord. t = 168
+8 +8
mp

7' 0" 7' 3" 7' 6" 7' 9" 7' 12" 7' 15"

00
90
80
70
60
50

7' 15" 7' 18" 7' 21" 7' 24" 7' 27" 7' 30"

gliss. t = 86 t = 113

-47 fū -48 tæ

mp mp

p.gl. p.gl. t = 88

-35 -6 +36 +40
ø hø ø fi

mp

t = 114 t = 95

mp mp

ord. t = 172

+8 +30

p mp

7' 15" 7' 18" 7' 21" 7' 24" 7' 27" 7' 30"

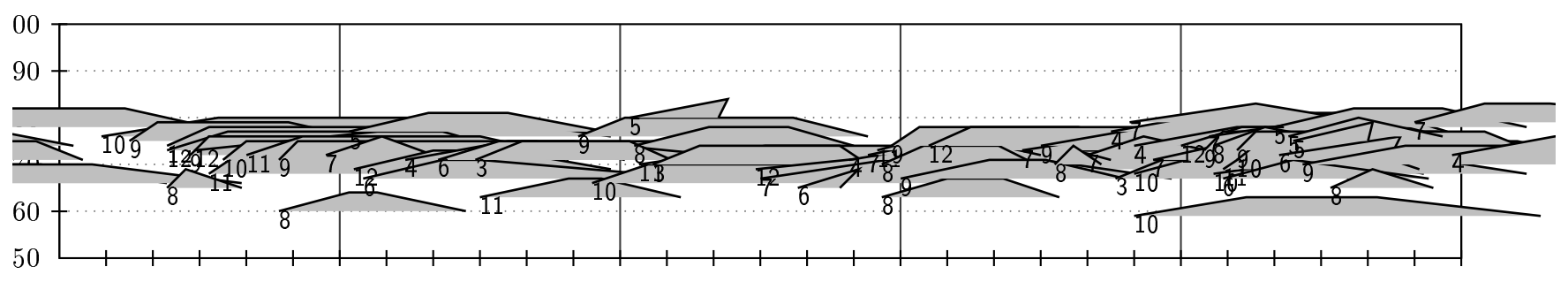

7' 30" 7' 33" 7' 36" 7' 39" 7' 42" 7' 45"

36 +40
ø fi

t = 106
+30 +20
dø dø
mp

t = 90
-13 +24 -45
hũ qø hø
mp

t = 106 mp

t = 94 mp

7' 30" 7' 33" 7' 36" 7' 39" 7' 42" 7' 45"

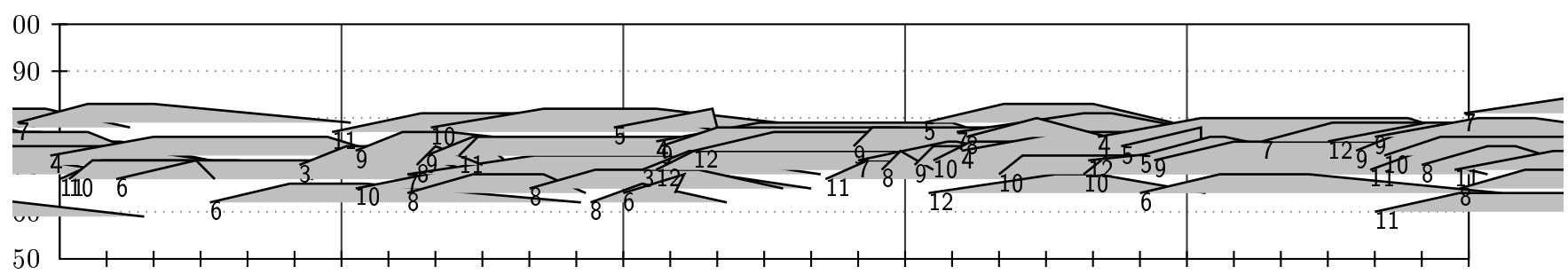

7' 45"	7' 48"	7' 51"	7' 54"	7' 57"	8' 0"
mp		mf		mp	mf

	mp				

7' 45" 7' 48" 7' 51" 7' 54" 7' 57" 8' 0"

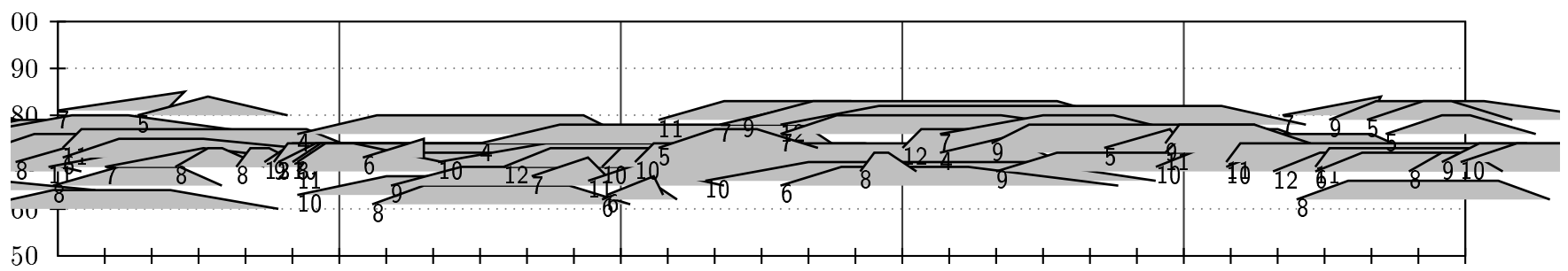

8' 0" 8' 3" 8' 6" 8' 9" 8' 12" 8' 15"

+47
rũ

-11 -21
qu ti

+6 -40
ah ũ

-17 +8
hũ wa

mf

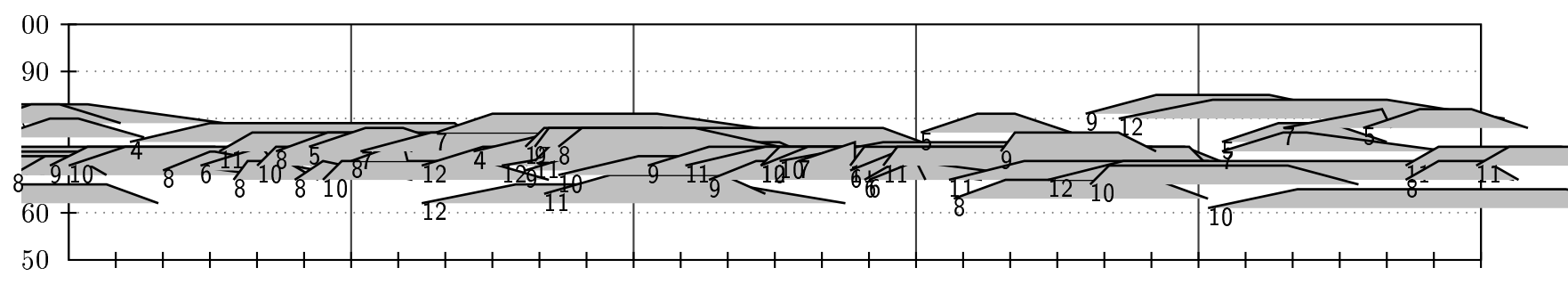
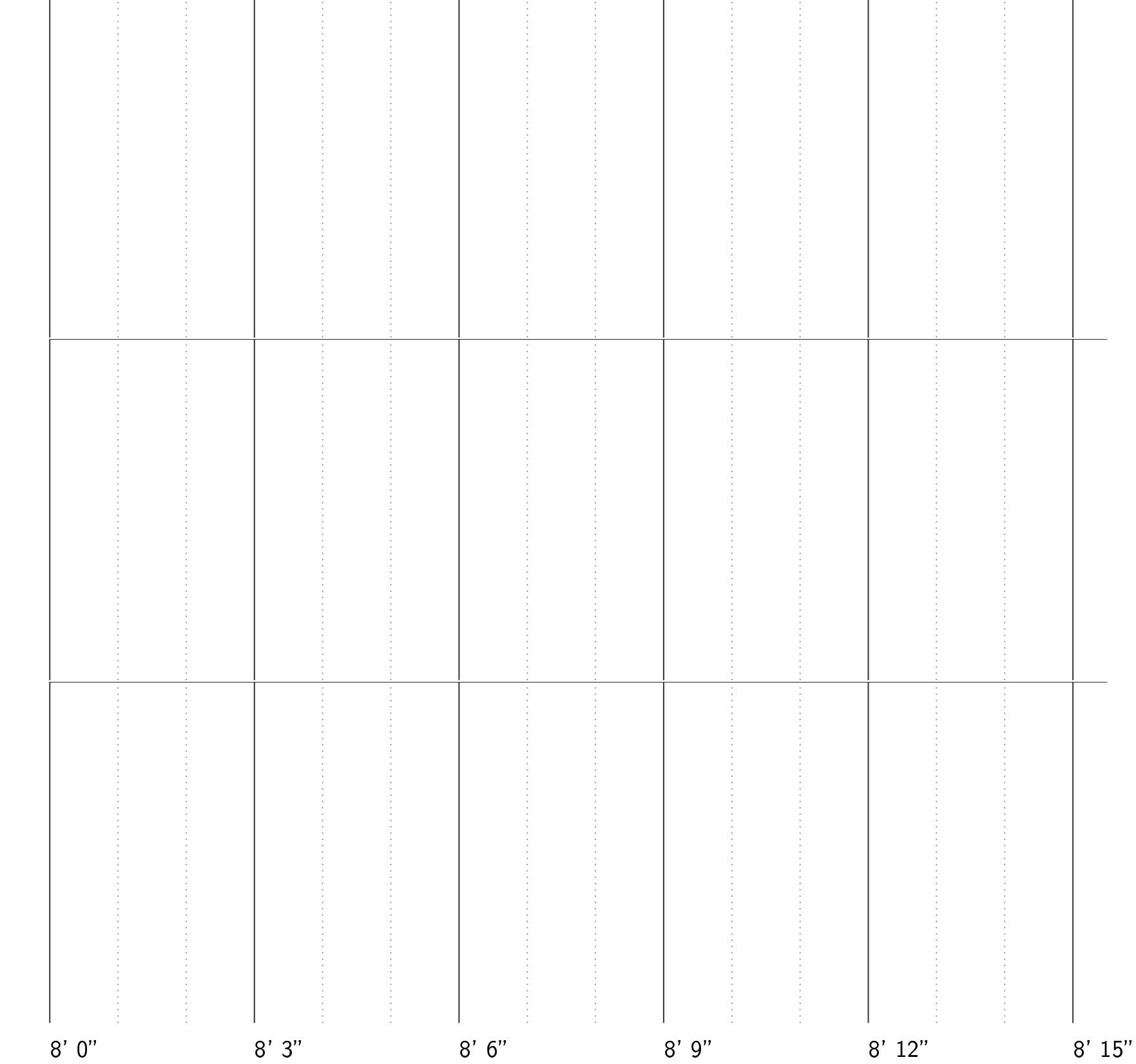

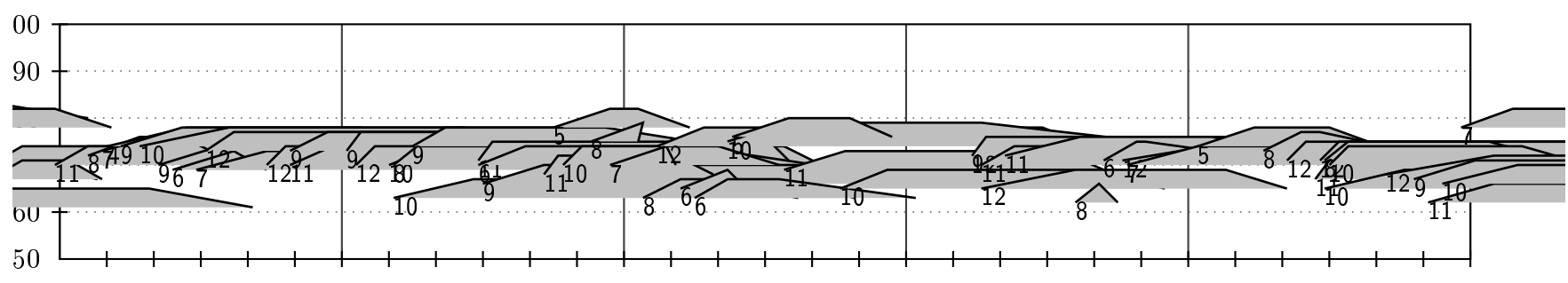
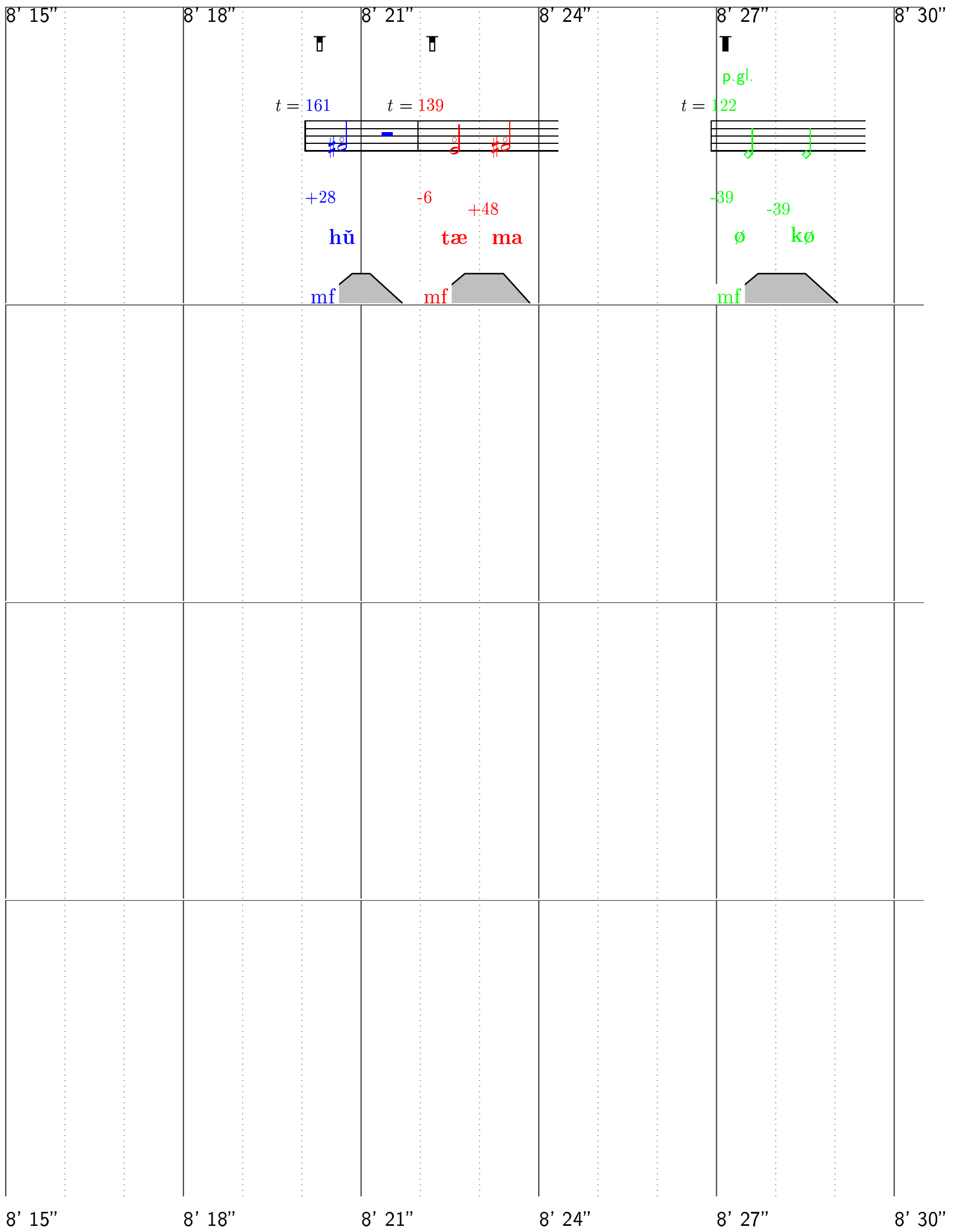

8' 30"	8' 33"	8' 36"	8' 39"	8' 42"	8' 45"
	<p>$t = 149$</p> <p>+16 +6</p> <p>ha wa</p> <p>mf</p>	<p>$t = 123$</p> <p>-28 +26</p> <p>ra tũ</p> <p>mf</p>			
8' 30"	8' 33"	8' 36"	8' 39"	8' 42"	8' 45"

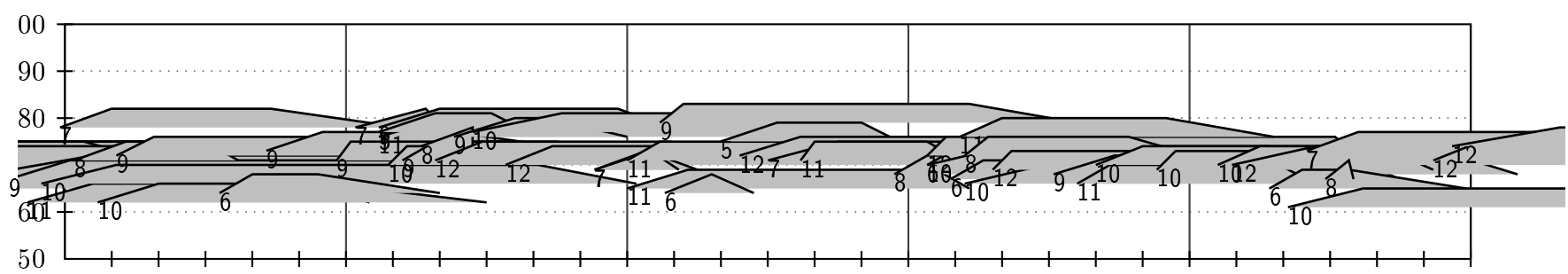

8' 45" 8' 48" 8' 51" 8' 54" 8' 57" 9' 0"

$t = 131$

-6 -6

fø hũ

mf

8' 45" 8' 48" 8' 51" 8' 54" 8' 57" 9' 0"

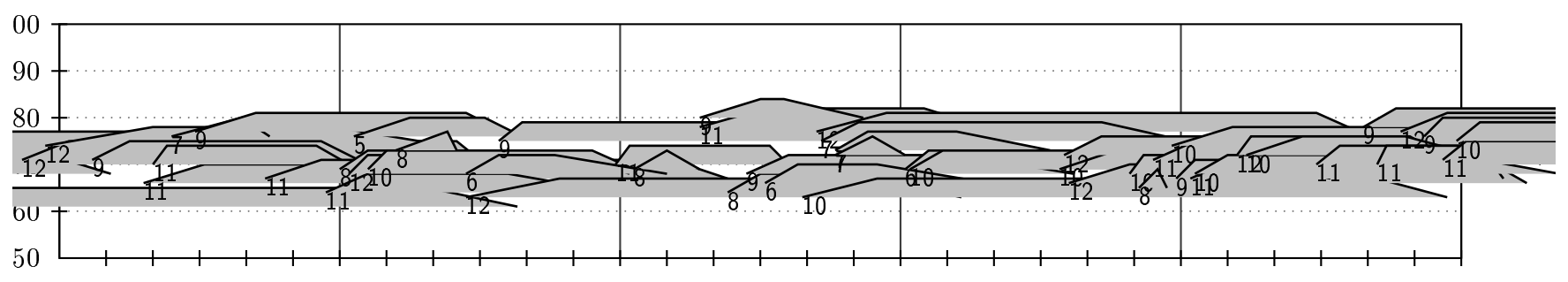

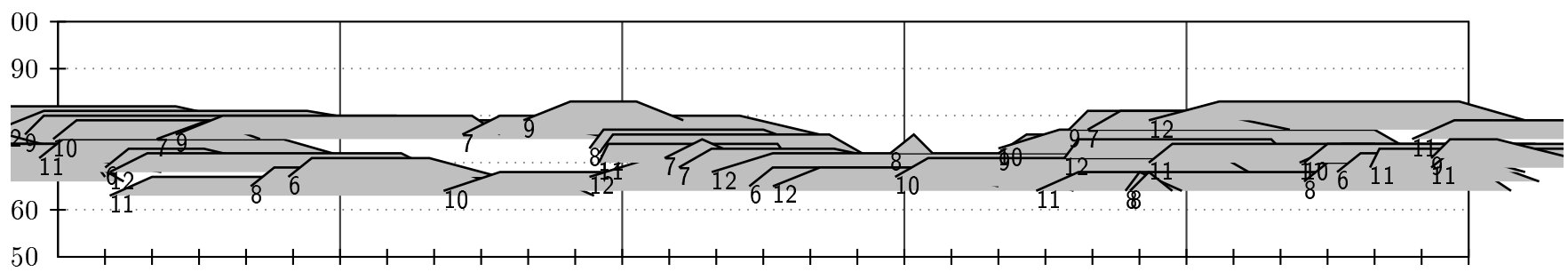
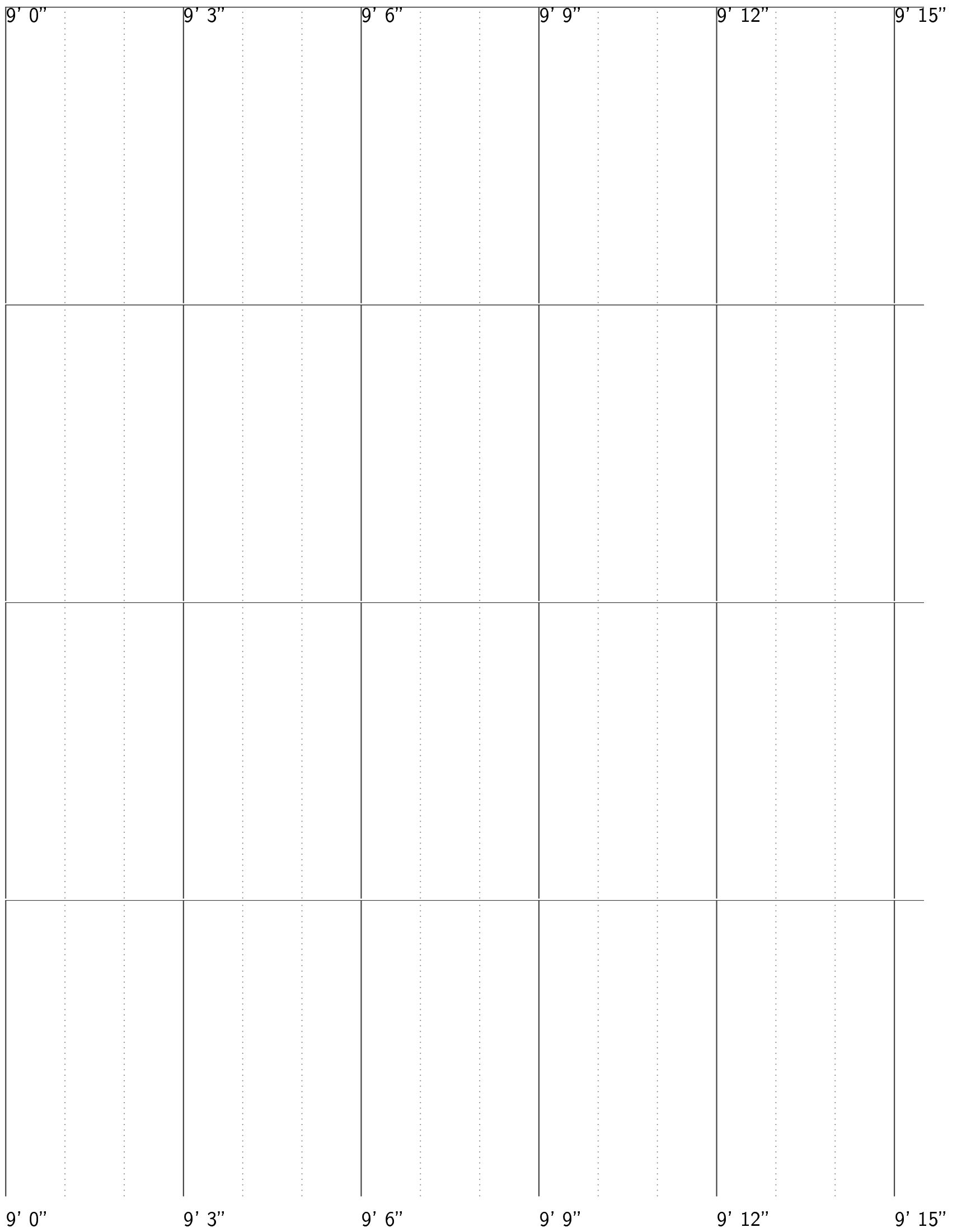

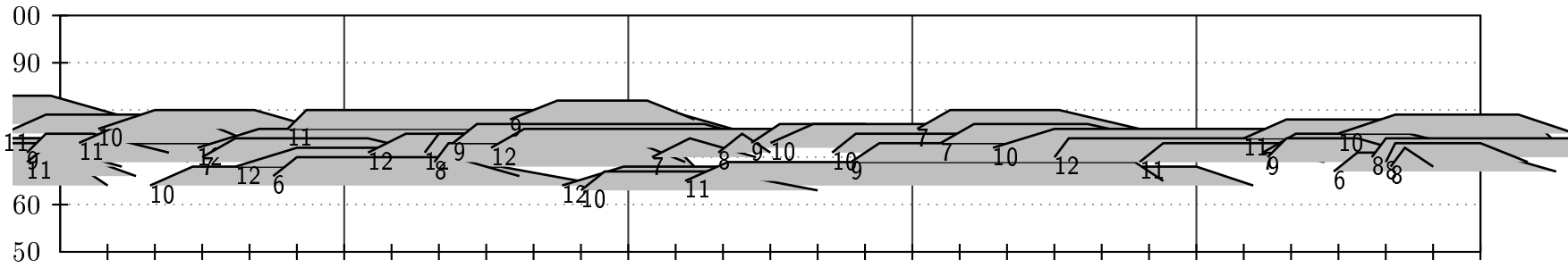
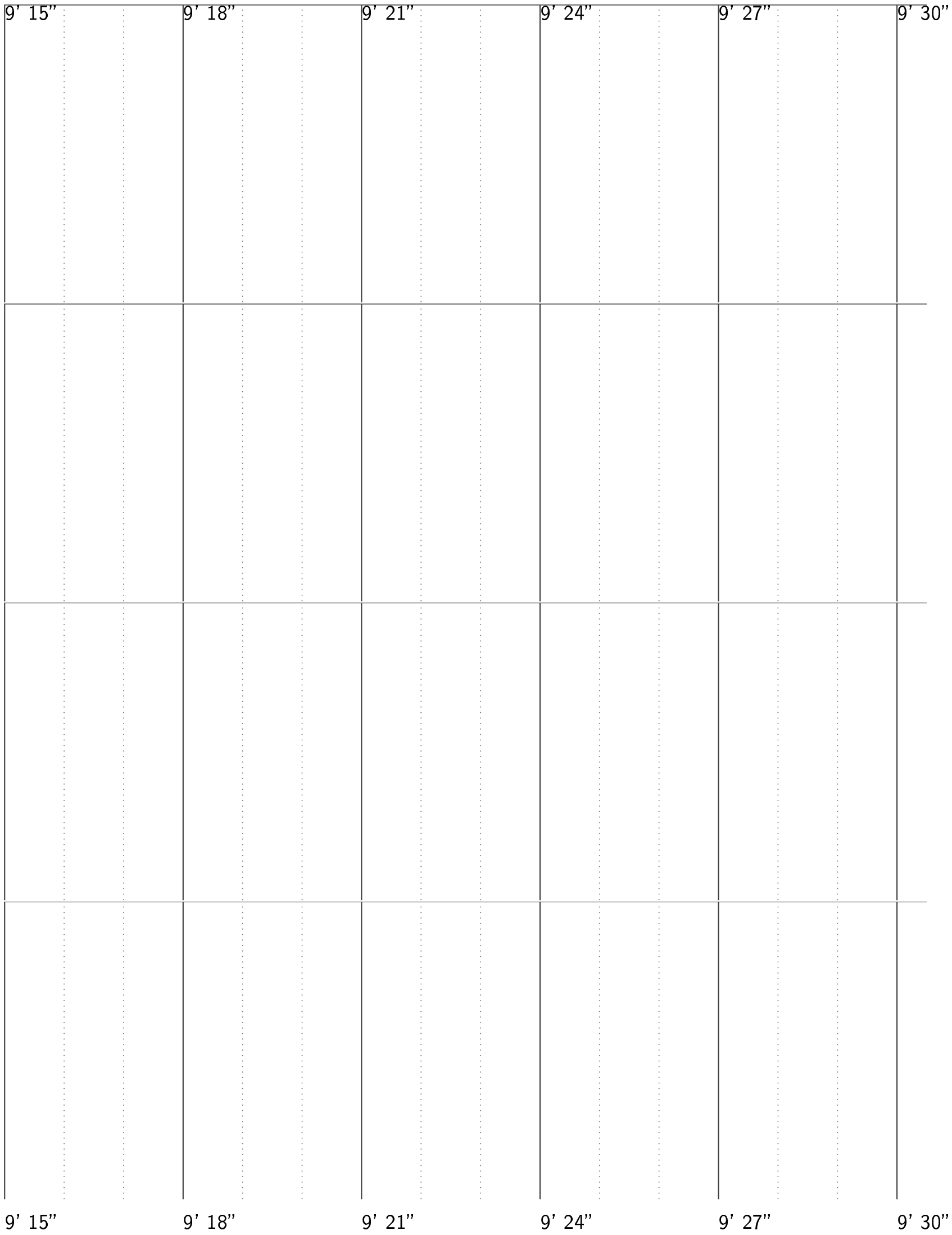

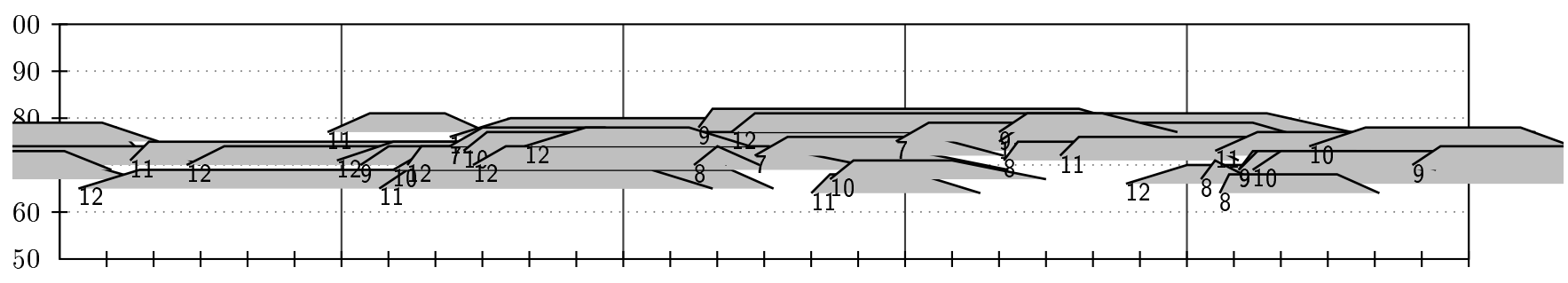
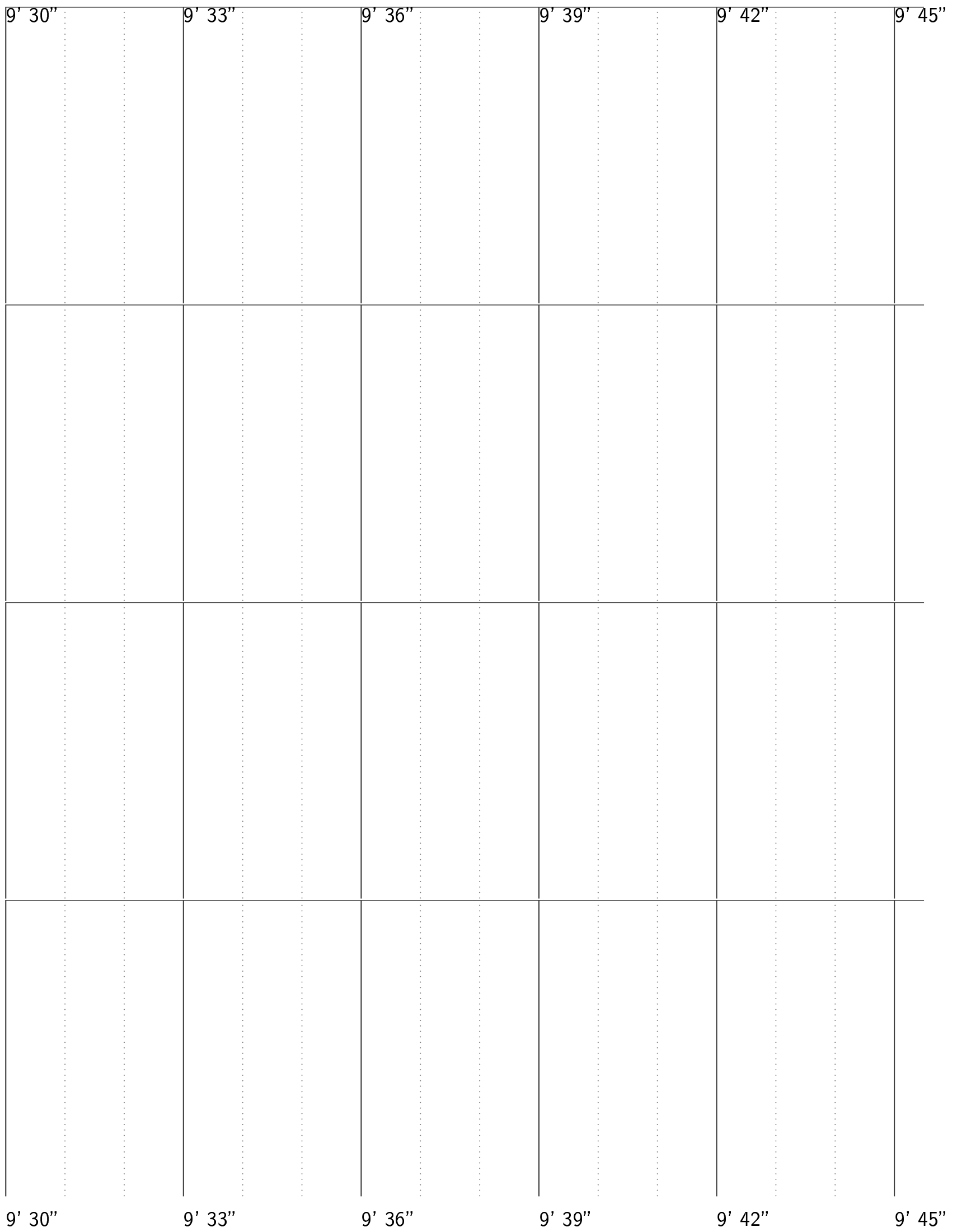



9' 45" 9' 48" 9' 51" 9' 54" 9' 57" 10' 0"

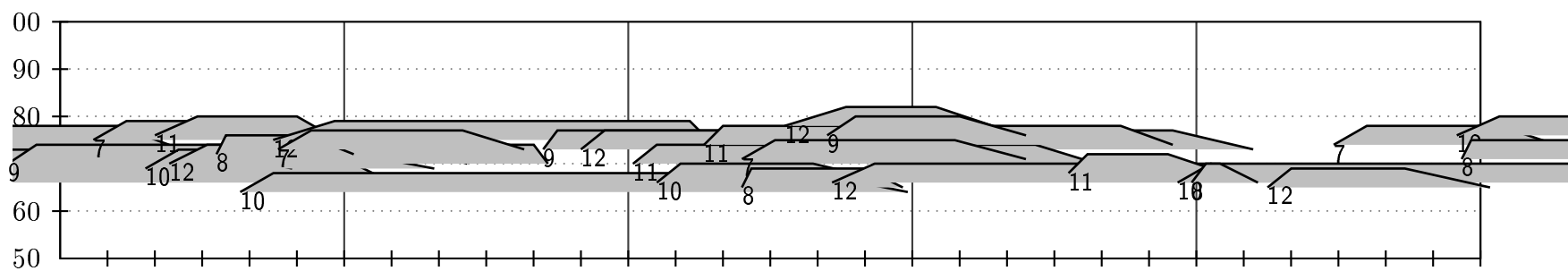



10' 0" 10' 3" 10' 6" 10' 9" 10' 12" 10' 15"

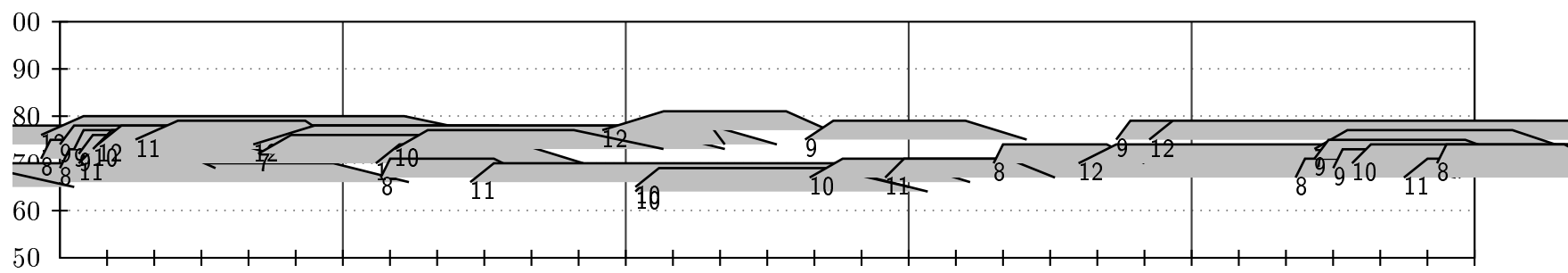



10' 15" 10' 18" 10' 21" 10' 24" 10' 27" 10' 30"

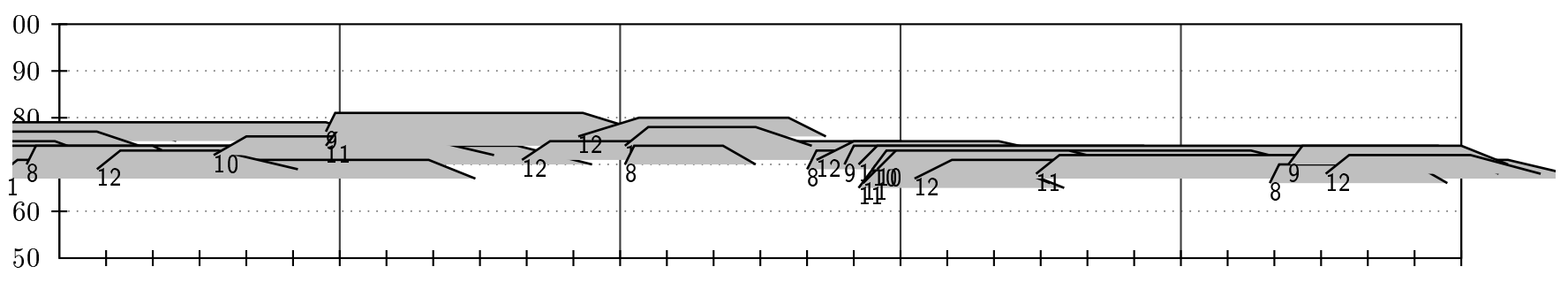



10' 30" 10' 33" 10' 36" 10' 39" 10' 42" 10' 45"

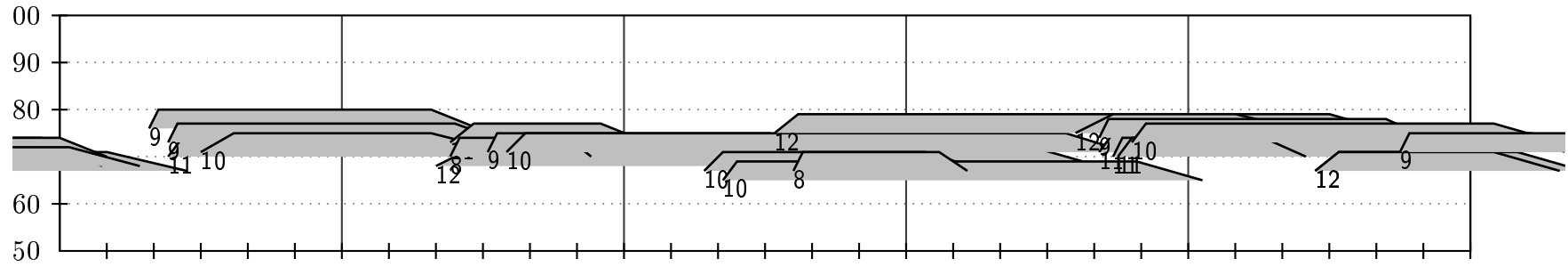



10' 45" 10' 48" 10' 51" 10' 54" 10' 57" 11' 0"

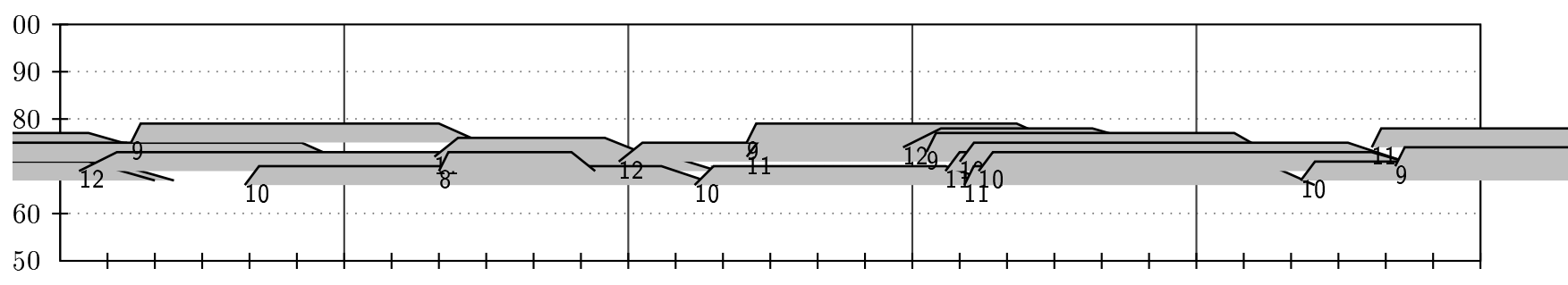



11' 0" 11' 3" 11' 6" 11' 9" 11' 12" 11' 15"

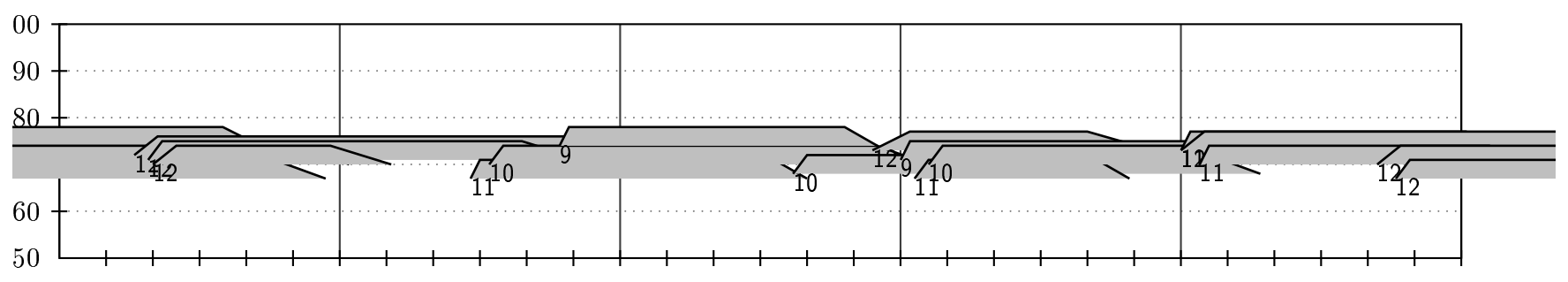



11' 15" 11' 18" 11' 21" 11' 24" 11' 27" 11' 30"

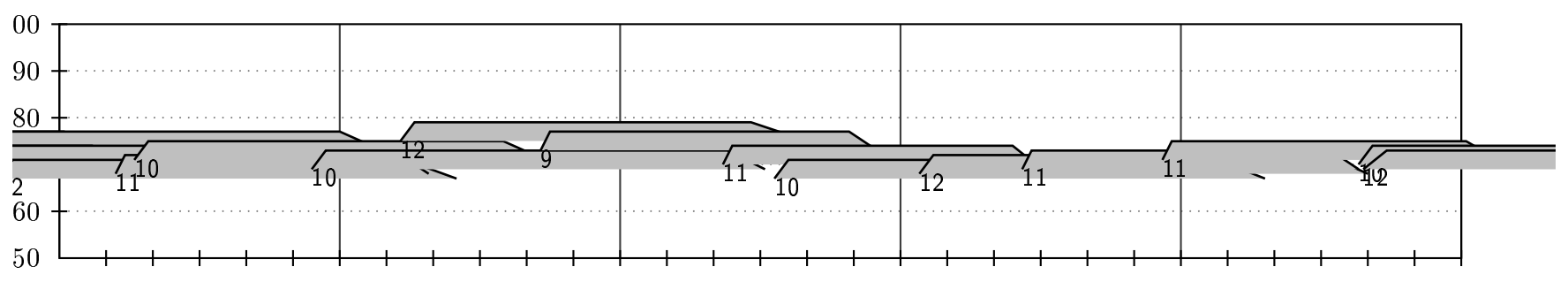



11' 30" 11' 33" 11' 36" 11' 39" 11' 42" 11' 45"

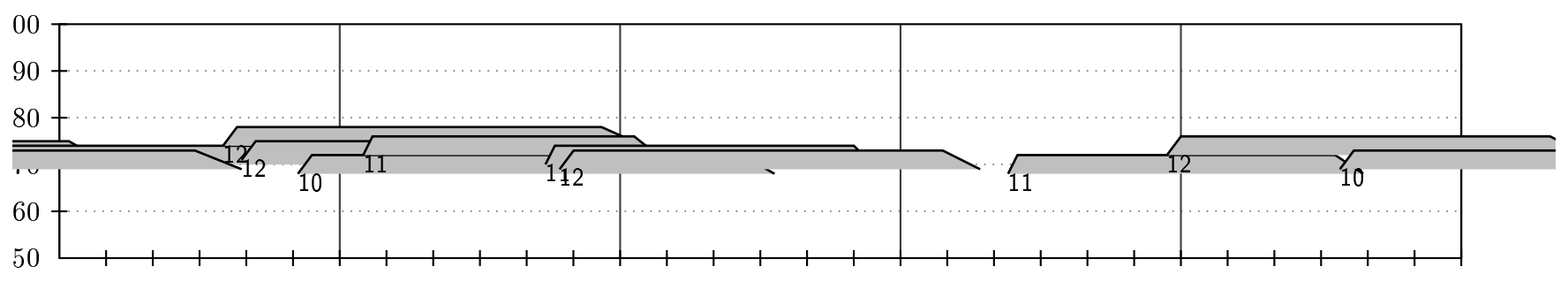



11' 45" 11' 48" 11' 51" 11' 54" 11' 57" 12' 0"

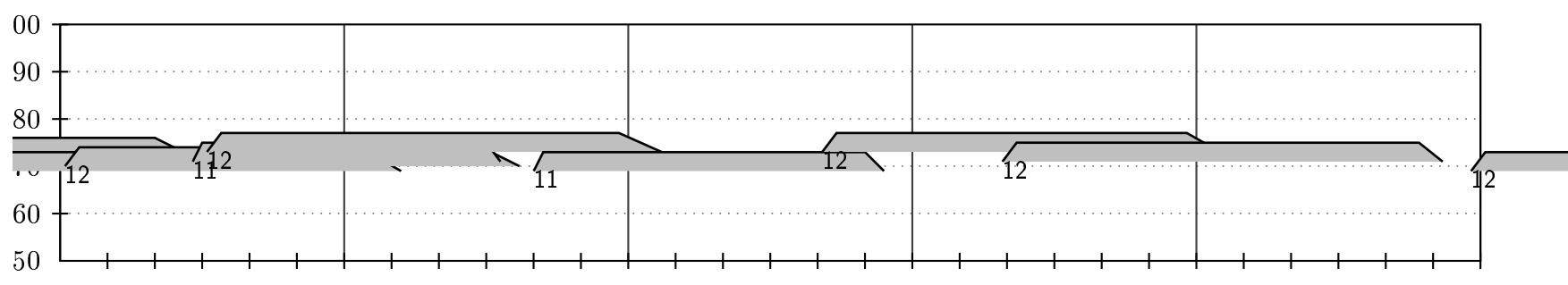



12' 0" 12' 3" 12' 6" 12' 9" 12' 12" 12' 15"

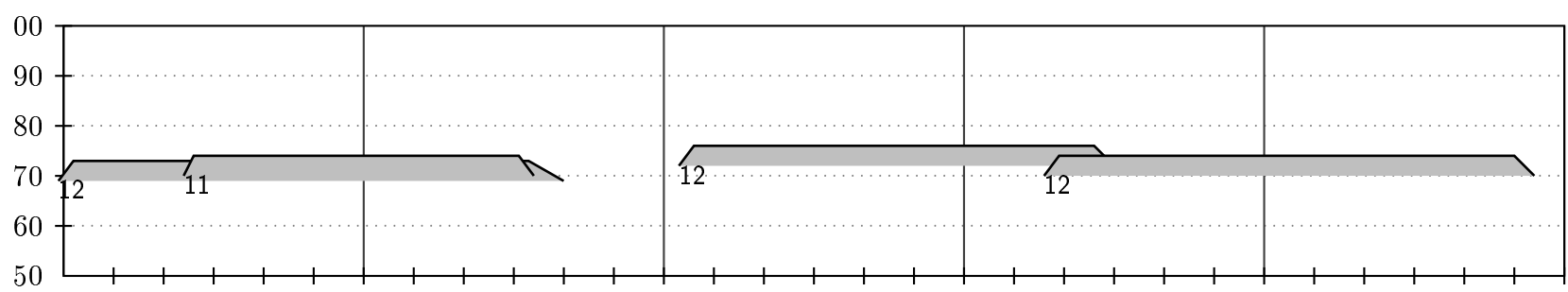



12' 15" 12' 18" 12' 21" 12' 24" 12' 27" 12' 30"

